

Accepted Manuscript

Registered Report

Sex Differences in the Big Five Model Personality Traits: A Behavior Genetics Exploration

Susan C. South, Amber M. Jarnecke, Colin E. Vize

PII: S0092-6566(18)30032-1
DOI: <https://doi.org/10.1016/j.jrp.2018.03.002>
Reference: YJRPE 3706

To appear in: *Journal of Research in Personality*

Received Date: 6 October 2015
Revised Date: 12 March 2018
Accepted Date: 21 March 2018

Please cite this article as: South, S.C., Jarnecke, A.M., Vize, C.E., Sex Differences in the Big Five Model Personality Traits: A Behavior Genetics Exploration, *Journal of Research in Personality* (2018), doi: <https://doi.org/10.1016/j.jrp.2018.03.002>

This is a PDF file of an unedited manuscript that has been accepted for publication. As a service to our customers we are providing this early version of the manuscript. The manuscript will undergo copyediting, typesetting, and review of the resulting proof before it is published in its final form. Please note that during the production process errors may be discovered which could affect the content, and all legal disclaimers that apply to the journal pertain.



RUNNING HEAD: SEX DIFFERENCES IN PERSONALITY

Sex Differences in the Big Five Model Personality Traits: A Behavior Genetics Exploration

RUNNING HEAD: SEX DIFFERENCES IN PERSONALITY

Sex Differences in the Big Five Model Personality Traits: A Behavior Genetics Exploration

Susan C. South, Ph.D.^{a*}

Amber M. Jarnecke, M.S.^{a*}

Colin E. Vize, B.A.^a

^a Department of Psychological Sciences, Purdue University, 703 Third Street, West Lafayette, IN, United States.

*Both authors contributed equally to this manuscript.

Correspondence concerning this article should be addressed to Susan C. South at 703 Third Street, West Lafayette, IN 47907. Email: ssouth@purdue.edu.

This research was supported by the John D. and Catherine T. MacArthur Foundation Research Network on Successful Midlife Development.

Abstract

The importance of genetic influences for the Five Factor/Big Five Model (BFM) traits is well established. Relatively understudied, however, are the presence and magnitude of sex differences in genetic and environmental variance of these traits. The current study tested if men and women differ 1) qualitatively in the genetic mechanisms, or 2) quantitatively, on the genetic and environmental variance, contributing to BFM personality domains. Results from a nationally representative U.S. adult twin sample (N=973 pairs) supported phenotypic (i.e., mean level) sex differences in three of five personality traits (i.e., Neuroticism, Agreeableness, Conscientiousness) but did not support genetic or environmental sex differences in any trait.

Keywords: personality, sex differences, behavior genetics, twin

Sex Differences in the Big Five Model Personality Traits: A Behavior Genetics Exploration

The Five Factor Model (FFM) and Big Five Model (BFM) of personality define the characteristic ways people think, feel, and behave using five higher-order domains: Neuroticism, Extraversion, Openness, Agreeableness, and Conscientiousness (Costa & McCrae, 1992; Goldberg, 1990; Oliver & Srivastava, 1995). The influence of genetics on these domains (hereafter referred to as the BFM, although we acknowledge differences in how the FFM/BFM conceptualize these domains) is now well established. Across several twin studies, research estimates that approximately 40-50% of the variation in the BFM domains is due to genetic variation (meta-analytic heritability estimate of .48, see Vukasovic & Bratko, 2015), with the majority of the remaining variance attributable to unique environmental differences between people (for a review, see Jarnecke & South, 2015). Research has found observed phenotypic sex differences in the BFM. Women, for instance, tend to have higher mean levels of Agreeableness and Neuroticism than men (Chapman, Duberstein, Sörensen, & Lyness, 2007; Costa, Terracciano, & McCrae, 2001; Feingold, 1994). Evidence for biometric sex differences is less consistent (see Bouchard & McGue, 2003). The current study aims to determine whether there are genetic and environmental sex differences in the BFM personality domains using behavior genetics modeling of a nationally representative sample of adult twins.

Genetic and Environmental Sex Differences in Personality

Behavior genetics methods use genetically informative family data (usually data from identical and fraternal twins) to examine the proportion of variance in a trait due to genetic influences and environmental influences. Genetic influences include the additive effects of all genes across all loci summed together (but can also comprise nonadditive effects, including dominance), shared environmental influences are those that lead to greater similarity among

members of the same family (e.g., presumably neighborhood, socioeconomic status), and nonshared environmental influences are those that make members of the same family different from one another (e.g., different peer groups, traumatic experiences). Many behavior genetics studies include sex as a covariate, but it is possible to examine sex differences more formally within a structural equation framework that estimates the proportions of genetic and environmental variance on a phenotype (i.e., observed variable). Using such an approach, a number of studies have tested for the presence of both *quantitative* sex differences and *qualitative* sex differences. Quantitative sex differences exist if the magnitude of the variance accounted for by genetic and environmental influences is different for men and women; such differences may reflect differing trait evolutionary histories between men and women (i.e., men and women may have encountered unique selective pressures over their respective evolutionary histories; Jang, Livesley, & Vernon, 1998). When there are sex differences in the type of heritable factors that contribute to a phenotype, this presents an example of qualitative sex differences, or sex-limited gene expression (Neale & Cardon, 1992). Specifically, qualitative sex differences may indicate different genes acting on a phenotype but also may indicate that men and women share the same genes but the genes specific to said phenotype are only expressed in women as opposed to men (or vice versa). Neale and Cardon (1992) provide an example of qualitative sex differences in the case of chest girth. Men and women share common genetic loci responsible for chest girth, but these genes are only fully expressed in women.

BFM Domains. To this point, there has been relatively limited research on biometric sex differences for the BFM domains. In a recent meta-analysis, Vukasovic and Bratko (2015) concluded that gender was not a significant moderator of the heritability of personality; however, this was a moderator analysis of heritability estimates calculated from twin correlations across

samples and across personality traits from several models of normal personality, not just the BFM. In a sample of adolescent twins, Loehlin, McCrae, Costa, and John (1998) examined sex differences in parameters of a basic univariate biometric model for the BFM domains (factors composed of indicators from ratings, questionnaire, and adjective check list), and reported that any sex differences in the model could be explained at the factor loading level, concluding that there were no important differences in heritability estimates as a function of sex. Of note, Loehlin and colleagues did not examine a model with qualitative sex differences in heritability estimates. Earlier work in the Swedish Adoption/Twin Study of Aging (SATSA) examined gender differences in three of the BFM domains (Openness, Conscientiousness, and Agreeableness), as assessed by a short version of the NEO-PI, and found that genetic effects were different only for Conscientiousness ($h^2 = 41\%$ men, $h^2 = 11\%$ women; Bergeman et al., 1993).

In addition to the studies listed above, there has been work conducting biometric modeling with measures of the BFM/FFM (i.e., one of several versions of the NEO; Jang, Livesley, & Vernon, 1996; Riemann, Angleitner, & Strelau, 1997); but researchers have failed to conduct sex limitation modeling (e.g., not enough male DZ pairs or opposite sex DZ pairs to conduct analyses, Jang et al., 1996). An advantage of the sample utilized in the current analyses (from the Midlife in the United States study; MIDUS) is that it is a nationwide sample of roughly similar numbers of opposite-sex dizygotic (OSDZ), same-sex DZ, and monozygotic (MZ) adult twin pairs; the inclusion of OSDZ twins is necessary to examine qualitative sex differences. One study using the same MIDUS twin sample examined the overlap between the BFM domains and subjective well-being, and in the process examined sex differences in the parameters of the model (Keyes, Kendler, Meyers, Martin, 2015). Across both bivariate and multivariate models,

they found no evidence of sex differences; however, they only examined quantitative differences and never ran independent models examining the BFM domains separately from subjective well-being.

Other Trait Models of Normal Personality. There is existing research examining biometric sex differences in personality traits from other models of normative personality. This work is informative in regards to the BFM, as factor analytic work suggests that when various measures of personality are modeled together, the structure tends to resemble the BFM (Markon, Krueger, & Watson, 2005). In a review of four older twin studies, Eaves and colleagues (1989) found mixed evidence for sex differences, with two studies comprising samples from London and the United States finding no evidence of differences in the magnitude of genetic influences on Extraversion or Neuroticism, a study with Australian twins finding evidence for sex specific effects on Neuroticism and variance differences in Psychoticism, and a Swedish study finding differences in magnitude for Neuroticism and Extraversion.

A study of Cloninger's (1986) personality model in 1,851 adolescent twins found no quantitative or qualitative sex differences in genetic or environmental influences for the higher order traits of Harm Avoidance, Novelty Seeking, and Reward Dependence (Heiman, Stallings, Young, & Hewitt, 2004); however, quantitative sex differences for environmental (shared and nonshared) influences were found for the trait of Persistence, such that shared environmental influences were greater for women ($c^2=.35$) than men ($c^2=.27$). In a sample of Australian adult twins and siblings, sex specific genetic effects were found for Reward Dependence and Harm Avoidance, whereas the type and size of genetic effects seemed to be generally equivalent across men and women for Novelty Seeking (Keller, Coventry, Heath, & Martin, 2005).

Other studies of biometric sex-limitation have also examined Eysenck's theory of personality using different versions of Eysenck measures (i.e., Eysenck Personality Questionnaire, Eysenck Personality Questionnaire short form, Eysenck Personality Inventory). For instance, one study used a combined sample of twin pairs and their families from Finland, Australia, and the United States to examine Extraversion and Neuroticism assessed from; Eaves, Heath, Neale, Hewitt, & Martin, 1998). Broad-sense heritability (a combination of both additive and nonadditive genetic influences) of Extraversion was roughly equivalent for men and women but non-additive genetic influences on Neuroticism were greater for men ($d^2 = 21.9\%$) compared to women ($d^2 = 13.1\%$). In a large ($N=45,850$) combined sample of Australian and U.S. twins and relatives, the broad heritability of Neuroticism differed between women ($H^2 = 41\%$) and men ($H^2 = 35\%$), but there were no sex specific genetic effects (Lake, Eaves, Maes, Heath, & Martin, 2000). A Finnish sample of adult twins assessed twice across six years found increased heritability with age for Neuroticism in women, but gender invariance of genetic influences on Extraversion (Viken, Rose, Kaprio, & Koskenvuo, 1994). Keller and colleagues also examined the EPQ in their sample of Australian adult twins and siblings, finding sex specific genetic effects for EPQ Neuroticism but generally equivalent genetic effects across sex for Extraversion and Psychoticism (Keller et al., 2005). A study of 3,301 Dutch adolescent twins also found support for quantitative sex differences in Neuroticism, such that the genetic variance was greater for women; however, the standardized estimates for genetic and environmental variance could be held equal in this sample (Rettew et al., 2006). A later study also using the Netherlands Twin Register sample found no evidence of sex specific genetic effects on Extraversion and no differences in the genetic and environmental components of variances between male and female adolescents (Rettew, Rebollo-Mesa, Hudziak, Willemsen, & Boomsma, 2008). In a sample of

Australian adolescent twins assessed at 12, 14, and 16, genetic and environmental influences could be constrained equal across men and women for Extraversion at all ages, but the relative contributions differed for Neuroticism at age 12 and Psychoticism at age 12 and 14 (Gillespie, Evans, Wright, & Martin, 2004).

Thus, in general, studies have found evidence for some differences in Neuroticism but no sex differences in the etiological influences on Extraversion. Other studies that have used the EPQ, however, support different conclusions. One study found no sex differences in heritability for Neuroticism but evidence for greater heritability of Extraversion in men (Macaskill, Hopper, White, & Hill, 1994), while another using combined twin data from multiple studies, found that both Neuroticism and Extraversion showed higher rates of heritability in men (Loehlin, 1982). Loehlin (2012), in a large sample of adult Australian twins ($N=1,771$), found some sex differences in the broad heritability estimates of cluster scores derived from items from the short-form Eysenck Personality Questionnaire (EPQ-R; Eysenck, Eysenck, & Barrett, 1985) and Tridimensional Personality Questionnaire (TPQ; Cloninger et al., 1991), which measures Cloninger's model; however, there was no identifiable pattern to these sex differences.

To our knowledge, only one study has examined genetic and environmental sex differences in Tellegen's (1982) model of personality. No qualitative or quantitative sex differences were found in the higher order domains of Positive Emotionality, Negative Emotionality, or Constraint (Finkel & McGue, 1997); however this investigation did find significant quantitative sex differences for the lower-order scales of Absorption, Control, and Alienation. Heritability estimates were higher for women for Absorption ($h^2=11\%$ for men, $h^2=29\%$ for women) and Control ($h^2=2\%$ for men, $h^2=20\%$ for women) while heritability was higher for men for Alienation ($h^2=25\%$ for men, $h^2=16\%$ for women). Jang, Livesley, and

Vernon (1998), however, pointed out that Finkel and McGue's inclusion of family data (i.e., siblings of the twin pairs) may have led to inconsistencies in the findings. Jang et al. note that Finkel and McGue reported sex-differences for Absorption when the correlations among the twin pairs were similar ($r_{dzm}=0.17$, $r_{dzf}=0.13$, $r_{dzo}=0.16$) while no sex-differences were reported for Social Potency, despite the appearance of sex-limited effects ($r_{dzm}=0.33$, $r_{dzf}=0.28$, $r_{dzo}=0.16$). Jang and colleagues (1998) ultimately argue that further exploration is needed to better understand potential sex-limited effects for personality traits.

Current Study

There is consistent support that the BFM personality domains are moderately heritable and the remainder of the phenotypic variance is largely explained by nonshared environmental factors (e.g., Bouchard & McGue, 2003; Jang et al., 1998; Loehlin, McCrae, Costa, & John, 1998; Jang, Livesley, & Vernon, 1996). To date, there has been little research using sex-limitation biometric models to explore genetic and environmental differences in the BFM domains (outside of Neuroticism and Extraversion as measured in other trait models), and none to our knowledge to examine qualitative differences in genetic influences. This is surprising, as identifying genetic and environmental sex differences in the BFM personality domains has the advantage of helping us understand the etiology and development of personality as conceptualized by the most widely used models of personality. If quantitative sex differences are found this would suggest that genetic and environmental factors differ in the extent to which they contribute to the variance in personality. If qualitative sex differences are found this would imply that different genetic mechanisms are contributing to how these personality domains are expressed in men and women.

Although previous research does not find a consistent pattern of sex-limitation in personality, the current study drew from the existing literature (e.g., using a version of the Eysenck Personality Questionnaire) and hypothesized that genetic and environmental sex differences would be present for Neuroticism and Extraversion (Eaves et al., 1989; Eaves et al., 1998; Keller et al., 2005; Lake et al., 2000; Loehlin, 1982; Macaskill et al., 1994; Rettew et al., 2006; Viken et al., 1994). (Low) Agreeableness and (low) Conscientiousness are the personality traits most consistently linked to externalizing psychopathology, which has shown little evidence of genetic sex differences. Therefore we hypothesized no genetic and environmental sex differences for these traits. As less research has shown support for sex limited models of traits akin to Openness, no sex difference was predicted for this trait.

Method

Participants

Participants were drawn from the MacArthur Foundation Survey of Midlife Development in the United States (MIDUS), a nationally representative study of individuals in the United States. Participants ranged in age from 25 to 74 years. A nationally representative twin subsample was recruited via a telephone survey (Kessler, Gilman, Thornton, & Kendler, 2004). Approximately 50,000 homes were telephoned and screened in order to determine if any twin pairs resided within the household. Of these respondents, 14.8% reported presence of the twin, and of these individuals, 60% provided permission to contact their co-twin. Nine hundred ninety-eight twins met eligibility for the study and agreed to participate. After eliminating 1) twin pairs who did not complete data following the twin screener and 2) twin pairs of indeterminate zygosity, 973 pairs (1883 twins) were included in the analyses. Twins self-reported their sex and the current sample contained 365 monozygotic (MZ, identical) twin pairs (171 male pairs, 194 female pairs) and

608 dizygotic (DZ, fraternal) twin pairs (136 male pairs, 213 female pairs, 259 opposite-sex pairs). The average age of the sample was 44.94 (SD=12.09). As this was a secondary data analysis, the current authors were not able to control the sample size to ensure an adequately powered study given the expected magnitude of effects being explored. However, previous work has used the current sample (Weiss, Bates, & Luciano, 2008) and a subset of this sample (N=490) (Johnson & Krueger, 2004) and found significant effects of moderate magnitude using the BFM traits. Of the participants in the current sample, 84.8% indicated they were “White,” 3.8% indicated they were “Black and/or African American,” 0.6% indicated they were “Native American Or Aleutian Islander/Eskimo,” 0.8% indicated “Other,” 0.3% indicated they were “Multiracial,” and 9.7% were missing data or refused to answer.

Procedures

Participants enrolled in MIDUS were assessed with a 45-minute computer-assisted telephone interview and completed two questionnaire booklets sent to them in the mail. In general, measures assessed constructs associated with physical and psychological well-being as well as social responsibility. Measures for the current study were drawn from the self-administered questionnaire. Data collection began in 1994, lasted 13 months, and ended in 1995.

Measures

Personality traits were measured with a scale developed for MIDUS to assess for the Big Five personality (Lachman & Weaver, 1997). This measure has been well-validated and has demonstrated strict measurement invariance across age groups for the five factor structure and factor loadings (Zimprich, Allemand, & Lachman, 2012)¹. Traits were measured with trait

¹ We found no published studies of measurement invariance across sex of the MIDUS BFM measure, thus we tested this within the MIDUS twin subsample using the default Mplus code to test metric, configural, and scalar invariance across sex. Each BFM trait demonstrated metric invariance except for Conscientiousness. Although according to standard fit indices (e.g., change in chi-square, CFI, TLI) the metric model still fit well, it was slightly above

adjectives selected from existing personality inventories. Neuroticism consists of ‘moody,’ ‘worrying,’ ‘nervous,’ ‘calm (reverse coded);’ Extraversion is measured with ‘outgoing,’ ‘friendly,’ ‘lively,’ ‘active,’ ‘talkative;’ Openness is comprised of ‘creative,’ ‘imaginative,’ ‘intelligent,’ ‘curious,’ ‘broad-minded,’ ‘sophisticated,’ ‘adventurous;’ Conscientiousness consists of ‘organized,’ ‘responsible,’ ‘hardworking,’ ‘careless (reverse coded);’ Agreeableness involves ‘helpful,’ ‘warm,’ ‘caring,’ ‘softhearted,’ ‘sympathetic.’ For each of the traits, participants were asked to report how much the adjectives described them. Each item was rated on a 4-point scale (1 ‘A lot’ to 4 ‘Not at all’) and trait scores were formed by calculating the mean. Higher scores reflect higher levels of that trait. The internal reliabilities were each of the traits were as follows: $\alpha = 0.76$ for Neuroticism, $\alpha = 0.78$ for Extraversion, $\alpha = 0.78$ for Openness; $\alpha = .55$ for Conscientiousness, $\alpha = 0.80$ for Agreeableness.

Data Analysis

The current study used biometric structural equation models fit to twin data. Biometric models compare MZ twin to DZ twins in order to parse the variance in a phenotype into that which is attributed to additive genetic (A), shared environmental (C), and nonshared environmental (E) influences. In attempt to identify genetic and environmental sex differences in the BFM personality traits, three models were tested: 1) a non-scalar sex limitation model which examined the extent to which there were qualitative sex differences in genetic influences on personality traits; 2) a scalar sex limitation model which assessed the degree to which there were quantitative sex differences in genetic and environmental influences on personality; 3) a

recommended guidelines for change in CFI from the baseline, configural model; however change in RMSEA was within recommended guidelines (see Chen, 2007). If we rely on change in chi-square and change in CFI, our findings would suggest that the factor loadings of Conscientiousness may not be equivalent between men and women; however, measurement invariance is a complex issue (Chen, 2007), as shown by the inconsistency of our change in CFI and change in RMSEA. Overall, we recommend using caution when interpreting our findings regarding Conscientiousness.

homogeneity model which held the genetic and environmental variances equal between men and women. As presented in Figure 1, the non-scalar model allows for the genetic correlation for opposite-sex DZ twins to be estimated freely, thus testing whether different genes influence personality in men compared to women; if there were no qualitative sex differences (i.e., the same genes operate in men and women) the genetic correlation would be .5. In addition, the ACE parameters (the paths from the latent genetic and environmental influences to the phenotype) were allowed to vary across men and women. The scalar sex limitation model was fit next. This model constrained the genetic correlation for opposite-sex DZ twins to .5, thus removing the possibility of qualitative sex differences; quantitative sex differences were tested by allowing the proportion of genetic and environmental variance to vary by a scalar value, such that even though the total phenotypic variance could differ by sex, the proportion of variance due to each component was held equivalent. Finally, the homogeneity model was fit to the data, holding parameter estimates and variances equal across sex (i.e., both unstandardized raw variances and standardized variances, including heritability, would be equivalent across men and women).

Personality traits were adjusted for the effects of age by regressing age out of each trait. For each of the five traits, twin correlations were examined and sex limitation models were fit to the data in OpenMx (Boker et al., 2012). Models were fit using full-information maximum likelihood. Fit of the model was assessed using several fit indices: -2 log-likelihood (LRT), Akaike Information Criterion (AIC; Akaike, 1987, and Bayesian Information Criterion (BIC). LRT is distributed as chi-square and lower values are favored. A statistically significant difference in LRT indicates improvement in model fit. AIC and BIC balance model fit with the number of parameters in the model. Lower values are reflective of better fitting models (Raftery, 1995).

Results

Descriptive Statistics and Correlations

Compared to the main, random digit dialing sample (i.e., non-sibling participants) in MIDUS, in our analysis of the data we found that the twin subsample received comparable scores on Extraversion ($t = -1.19$, $df = 4755$, $p = .23$; $d = -.03$) and Neuroticism ($t = .10$, $df = 4748$, $p = .92$; $d = .00$), had significantly higher scores on Agreeableness ($t = -2.61$, $df = 4755$, $p = .01$; $d = -.08$) and Conscientiousness ($t = 4.57$, $df = 4748$, $p < .001$; $d = .08$), and significantly lower scores on Openness ($t = -2.58$, $df = 3810.87$, $p = .01$; $d = -.14$). Means and standard deviations for the BFM traits in twins are reported in Table 1 separately by sex; Cohen's d was also calculated in order to estimate effect sizes. Female twins reported significantly higher rates of Neuroticism, Agreeableness, and Conscientiousness than male twins, though the effect sizes for Neuroticism and Conscientiousness were small (see Table 1).

Table 2 presents the intraclass correlations (ICCs) between twin pairs for each personality trait. As shown, MZ correlations were greater than DZ correlations for all traits, suggesting the presence of genetic influences. When DZ correlations are less than half of the MZ correlations this implies the presence of nonadditive genetic effects and when DZ correlations are greater than half of the MZ correlations shared environmental influences are indicated.² When patterns of MZ and DZ correlations differ for men and women this suggests the potential for sex-limited genetic effects. For Neuroticism, Openness, and Conscientiousness the MZ correlations were roughly double the DZ correlations. For Extraversion, the MZ female correlation was more than

² To examine the possibility of nonadditive genetic effects, we ran and compared ACE, ADE and AE models using the full twin sample grouped into MZ and DZ only. For all 5 BFM traits, an AE model fit better than the ADE model according to BIC (see supplementary table). Simulations have demonstrated greater accuracy of estimates from the full ACE model than those derived from submodels, in which one of the ACE parameters is set to 0 (e.g., an AE model; Sullivan & Eaves, 2002), thus we conducted sex limitation of full ACE biometric models, as opposed to submodels.

7 times the DZ female correlation but the MZ male correlation was only 2.42 times the DZ male correlation, thus suggesting the potential for sex-limited genetic effects. For Agreeableness, the MZ female correlation was 2.15 times the DZ female correlation whereas the MZ male correlation was 0.32 and the DZ male correlation was nearly 0.00. This, again, suggests the possibility of sex-limited effects.

Genetic and Environmental Sex Differences in FFM Personality Traits

Table 3 provides model fit statistics for the non-scalar sex limitation, scalar sex limitation, and homogeneity models for each BFM trait. Across the five traits, results suggest that the homogeneity model provided the best, most parsimonious fit to the data according to the difference in -2LL, AIC, and BIC; however, the homogeneity model for Agreeableness almost resulted in a significant decrease in fit compared to the scalar sex limitation model. Overall, these results indicate that there are no sex differences in the genetic and environmental influences contributing to the BFM personality traits.

Because sex differences in the BFM traits were not found, Table 4 provides unstandardized and standardized ACE estimates (and 95% confidence intervals) from the homogeneity model for each trait. Across traits, heritability ranged from 27% (Openness) to 36% (Conscientiousness). Shared environmental influences contributed a small (2% for Agreeableness to 15% for Openness) proportion of the variance and nonshared environmental influences contributed a substantial proportion of the variance for each personality domain (53% for neuroticism to 67% for Agreeableness).

Discussion

Phenotypic sex differences in BFM personality traits (i.e., mean level differences) have been well-documented over the last several decades. To date, no research has examined both

qualitative and quantitative genetic and environmental sex differences of the BFM personality traits in adult twins. What research does exist found sex differences only in one of three BFM domains (Conscientiousness; Bergeman et al., 1993), no sex differences in the BFM domains in adolescents (Loehlin et al., 1998), and no sex differences when considered together with other individual differences (i.e., well-being; Keyes et al., 2014). Research that has examined sex differences in the etiology of personality using other personality models (e.g., the Eysenck and Tellegen models) has been inconsistent, although there is a balance of the evidence in favor of sex differences in Neuroticism and possibly Extraversion ((Eaves et al., 1989; Eaves et al., 1998; Keller et al., 2005; Lake et al., 2000; Loehlin, 1982; Macaskill et al., 1994; Rettew et al., 2006; Viken et al., 1994). Thus, the goal of the present study was to determine if the same genetic influences were operating in men and women for the BFM higher-order domains, and if the magnitude of genetic and environmental variance on the BFM domains was equivalent across sex.

Results from the current study indicated significant phenotypic sex differences in the traits of Neuroticism, Agreeableness, and Conscientiousness, but, with the exception of Agreeableness, the sizes of these effects were small. Our findings did not support differences in the genetic and environmental architecture between men and women, as the results for all five BFM domains suggested that 1) the same genetic influences were operating in men and women, and 2) the magnitude of genetic and environmental variance was equivalent across sex.

To the best of our knowledge, this was the first study to examine *both* quantitative and qualitative biometric sex differences in the BFM domains in a nationally representative adult twin sample. Our results fit well with other studies that reported no sex differences in the BFM domains in adults (Bergeman et al., 1993) or in adolescents (Loehlin et al., 1998) or the BFM

domains in MIDUS as analyzed concurrently with subjective well-being (Keyes et al., 2014).

Findings from the current study are also consistent with a recent meta-analysis that examined the heritability of personality across 62 effect sizes (Vukasovic & Bratko, 2015). This meta-analysis, which examined personality traits from four major models of personality (i.e., Cattell, Eysenck, Tellegen, FFM) found that sex did not moderate heritability estimates.

Findings from the present investigation are somewhat inconsistent with other studies that have uncovered sex differences in etiological influences on personality (e.g., Eaves et al., 1989; Eaves et al., 1998; Keller et al., 2005; Lake et al., 2000; Loehlin, 1982; Macaskill et al., 1994; Viken et al., 1994). Although some studies have found that genetic variance in other higher-order domains of personality from alternative trait models differed by sex, in general it can be difficult to uncover sex differences at the domain level (see Loehlin, 1982). It is possible that genetic and environmental sex differences may be present in the lower-order BFM personality facets but not the higher-order domains, particularly because not all of the domains may be etilogically coherent (see Johnson & Krueger, 2004). In the present investigation, our measure of the BFM traits did not include the facet-level indicators, but future projects may want to include such assessments in order to identify possible sex differences in the personality facets. It is also possible that genetic and environmental sex differences in personality are less apparent in adult samples. For instance, Meier, Slutske, Heath, and Martin (2011) found support for qualitative sex differences in childhood conduct disorder but no biometric sex differences in adult antisocial behavior. Because these disorders are characterized by low Agreeableness and low Conscientiousness (e.g., Miller, Lynam, & Leukefeld, 2003), examining the five factor traits in child and adolescent samples may also produce results that differ from the current findings with an adult sample.

Even though we did not find support for genetic and environmental sex differences in the BFM traits, findings from the current study do inform our understanding of the etiology of personality. Most of the environmental variance in the BFM traits found in the current study was nonshared. This suggests that unique, idiosyncratic environmental experiences serve to make twins in the same family more dissimilar. Nonshared environmental influences are difficult to identify, but could include things such as prenatal factors, socialization, and culturally-perceived gender roles (see Helgeson, 2015; Jacklin & Reynolds, 1993 for reviews). Of course, it is important to note that researchers have argued that the magnitude of shared environmental effects, and the ratio of additive to nonadditive genetic influences, are best examined with extended twin family designs instead of classical twin designs (Keller, Medland, & Duncan, 2010). If supported, our results do have implications for molecular genetic studies of the BFM domains; measured genes for BFM and other personality trait model domains have been difficult to find (see Jarnecke & South, 2015) but our findings would suggest that it will not be necessary to look for different genes, or the same genes in different proportions, in men and women.

Limitations

This study is not without limitations. First, although our participants were drawn from a national sample of twins, our sample size was modest for an investigation that employs behavior genetics methods. Although we believe we had enough power in this investigation, biometric sex differences take a large number of twins to detect effects. In the current study, there was a near significant decrease in adequate model fit between the scalar sex limitation model and the homogeneity model for Agreeableness. Perhaps with a larger sample size we would have had the power to detect that the genetic and environmental variance in Agreeableness in fact differed by sex. Second, our measure of the BFM traits was somewhat limited. It consisted of a relatively

small number of trait-adjectives to assess each domain and, as noted above, did not allow for tests of facet-level traits. It is possible that sex differences would have been found for BFM facets rather than domains. Even though we found significant phenotypic differences for three of the traits, effects sizes for Neuroticism and Conscientiousness were smaller compared to other studies that examine the FFM domains (e.g., Costa et al., 2001). Further, because Conscientiousness did not meet metric invariance across sex (see Footnote 1) and because the alpha reliability for Conscientiousness was relatively poor, findings for this model should be interpreted with caution. Finally, our measure of personality was self-report and results may have differed if informant-report measures were used (e.g., Kandler et al., 2010).

Conclusions

Overall, our results suggest that genetic and environmental variance on the BFM traits does not differ by sex; phenotypic sex differences (i.e., mean level differences) were detected but were of a smaller magnitude compared to previously reported sex differences (e.g. Costa, Terracciano, McCrae, 2001). Nevertheless, these findings provide additional information about the etiology of personality, suggesting that observed sex differences in personality are likely due to other biological and social factors, and lending support to the idea that future research should continue to explore how these other factors contribute to the development of personality differences in men and women.

References

- Akaike, H. (1987). Factor analysis and AIC. *Psychometrika* 52, 317–332.
- Bem, S. L. (1974). The Measurement of psychological androgyny. *Journal of Consulting and Clinical Psychology*, 42(2), 155–162. doi:10.1037/h0036215
- Bergeman, C. S., Chlpuer, H. M., Plomin, R., Pedersen, N. L., McClearn, G. E., Nesselroade, J. R., . . . McCrae, R. R. (1993). Genetic and environmental effects on openness to experience, agreeableness, and conscientiousness: An adoption/twin study. *Journal of Personality*, 61, 159-179.
- Boker, S., Neale, M., Maes, H., Wilde, M., Spiegel, M., Spies, J., . . . Fox, J. (2012). OpenMx: An open source extended structural equation modeling framework, *Psychometrika*, 76(2), 306–317. doi:10.1007/s11336-010-9200-6.OpenMx
- Chapman, B. P., Duberstein, P. R., Sörensen, S., & Lyness, J. M. (2007). Gender differences in Five Factor Model personality traits in an elderly cohort. *Personality and Individual Differences*, 43(6), 1594–1603. doi:10.1016/j.paid.2007.04.028
- Chen, F.F. (2007). Sensitivity of goodness of fit indexes to lack of measurement invariance. *Structural Equation Modeling*, 14(3), 464-504.
- Cloninger, C. R. (1986). A unified biosocial theory of personality and its role in the development of anxiety states. *Psychiatric Developments*, 4, 167–226.
- Cloninger, C. R., Przybeck, T. R., & Svrakic, D. M. (1991). The tridimensional personality questionnaire: U.S. normative data. *Psychological Reports*, 69, 1047-1057.
- Costa, P., & McCrae, R. (1992). Normal Personality Assessment in Clinical Practice: The NEO Personality Inventory. *Psychological Assessment*, 4(1), 5–13. doi:10.1037//1040-3590.4.1.5

- Costa, P. T., Terracciano, A., & McCrae, R. R. (2001). Gender differences in personality traits across cultures: robust and surprising findings. *Journal of Personality and Social Psychology, 81*(2), 322–331. doi:10.1037/0022-3514.81.2.322
- Eaves, L.J., Eysenck, H.J., & Martin, N.G. (1989). Genes, culture and personality: An empirical approach. New York: Academic Press.
- Eaves, L. J., Heath, A. C., Neale, M. C., Hewitt, J. K., & Martin, N. G. (1998). Sex differences and non-additivity in the effects of genes on personality. *Twin Research: The Official Journal of the International Society for Twin Studies, 1*, 131–137. doi:10.1375/twin.1.3.131
- Eysenck, H. J., & Eysenck, S. B. G. (1975). *Manual of the Eysenck Personality Questionnaire*. Sevenoaks, UK: Hodder and Stoughton.
- Eysenck, S.B.G., Eysenck, H.J., & Barrett, P. (1985). A revised version of the psychoticism scale. *Person. Indiv. Diff., 6*(1), 21-29.
- Feingold, A. (1994). Gender differences in personality: a meta-analysis. *Psychological Bulletin, 116*(3), 429–456. doi:10.1037/0033-2909.116.3.429
- Finkel, D., & McGue, M. (1997). Sex differences and nonadditivity in heritability of the Multidimensional Personality Questionnaire Scales. *Journal of Personality and Social Psychology, 72*(4), 929–38.
- Floderus-Myrhed, B., Pedersen, N., & Rasmuson, I. (1980). Assessment of heritability for personality, based on a short-form of the Eysenck personality inventory: A study of 12,898 twin pairs. *Behavior Genetics, 10*, 153-162.
- Gillespie, N. A., Evans, D. E., Wright, M. M., & Martin, N. G. (2004). Genetic simplex modeling of Eysenck's dimensions of personality in a sample of young Australian twins. *Twin Research, 7*, 637–648.

- Goldberg, L. R. (1990). An alternative “description of personality”: The Big-Five factor structure. *Journal of Personality and Social Psychology*, *59*(6), 1216–1229.
doi:10.1037/0022-3514.59.6.1216
- Heiman, N., Stallings, M. C., Young, S. E., & Hewitt, J. K. (2004). Investigating the genetic and environmental structure of Cloninger’s personality dimensions in adolescence, *Twin Research*, *7*(5), 462–470.
- Helgeson, V. S. (2015). Gender and Personality. In M. Mikulincer & P. R. Shaver (Eds.), *APA Handbook of Personality and Social Psychology* (4th ed., pp. 515–534). American Psychological Association.
- Jacklin, C. N., & Reynolds, C. (1993). Gender and childhood socialization. In A. E. Beall & R. J. Sternberg (Eds.), *The Psychology of Gender* (pp. 197–214). New York, NY: Guilford Press.
- Jang, K. L., Livesley, W. J., & Vernon, P. a. (1996). Heritability of the big five personality dimensions and their facets: a twin study. *Journal of Personality*, *64*(3), 577–91.
- Jang, K. L., Livesley, W. J., & Vernon, P. a. (1998). A twin study of genetic and environmental contributions to gender differences in traits delineating personality disorder. *European Journal of Personality*, *12*(5), 331–344.
- Jang, K. L., McCrae, R. R., Angleitner, A., Riemann, R., & Livesley, W. J. (1998). Heritability of facet-level traits in a cross-cultural twin sample: Support for a hierarchical model of personality. *Journal of Personality and Social Psychology*, *74*, 1556–1565.
doi:10.1037/0022-3514.74.6.1556
- Jarnecke, A.M. & South, S.C. (2015). Behavioral and molecular genetics of the Five Factor Model. In T. Widiger (Ed.), *Oxford Handbook of the Five Factor Model*. Oxford University Press.

- Johnson, W., & Krueger, R. F. (2004). Genetic and environmental structure of adjectives describing the domains of the Big Five Model of personality: A nationwide US twin study. *Journal of Research in Personality, 38*, 448–472. doi:10.1016/j.jrp.2003.11.001
- Kandler, C., Bleidorn, W., Riemann, R., Spinath, F. M., Thiel, W., & Angleitner, A. (2010). Sources of cumulative continuity in personality: A longitudinal multiple-rater twin study. *Journal of Personality and Social Psychology, 98*(6), 995–1008. doi:10.1037/a0019558
- Keller, M. C., Coventry, W. L., Heath, A. C., & Martin, N. G. (2005). Widespread evidence for non-additive genetic variation in Cloninger's and Eysenck's personality dimensions using a twin plus sibling design. *Behavior Genetics, 35*, 707-721.
- Keller, M. C., Medland, S. E., & Duncan, L. E. (2010). Are extended twin family designs worth the trouble? A comparison of the bias, precision, and accuracy of parameters estimated in four twin family models. *Behavior Genetics, 40*, 377-393.
- Kessler, R. C., Gilman, S. E., Thornton, L. M., & Kendler, K. S. (2004). Health, wellbeing, and social responsibility in the MIDUS twin and sibling subsamples. In O. G. Brim, C. D. Ryff, & R. C. Kessler (Eds.), *How healthy are we?: A national study of wellbeing at midlife* (pp. 124–152). Chicago: University of Chicago Press.
- Keyes, C. L. M., Kendler, K. S., Myers, J. M., & Martin, C. C. (2014). The genetic overlap and distinctiveness of flourishing and the big five personality traits. *Journal of Happiness Studies, 16*, 655-668.
- Lachman ME, Weaver SL. (1997). The Midlife Development Inventory (MIDI) Personality Scales: Scale construction and scoring. Technical Report.
- Lake, R. I. E., Eaves, L. J., Maes, H. H., Heath, A. C., & Martin, N. G. (2000). Further evidence against the environmental transmission of individual differences in neuroticism from a

- collaborative study of 45,850 twins and relatives on two continents. *Behavior Genetics*, 30, 223–233.
- Löckenhoff, C. E., Chan, W., McCrae, R. R., Fruyt, F. De, Jussim, L., Bolle, M. De, ... Allik, J. (2014). Gender stereotypes of personality: Universal and accurate? *Journal of Cross-Cultural Psychology*, 45(5), 675–694. doi:10.1177/0022022113520075
- Loehlin, J. C. (1982). Are personality traits differentially heritable? *Behavior Genetics*, 12(4), 417–428.
- Loehlin, J. C. (2012). The differential heritability of personality item clusters. *Behavior Genetics*, 45, 500–507. doi:10.1007/s10519-011-9515-9
- Loehlin, J. C., McCrae, R. R., Costa, P. T., & John, O. P. (1998). Heritabilities of common and measure specific components of the big five personality factors. *Journal of Research in Personality*, 32: 431-43(32), 431–453.
- Macaskill, G. T., Hopper, J. L., White, V., & Hill, D. J. (1994). Genetic and environmental variation in Eysenck Personality Questionnaire scales measured on Australian adolescent twins. *Behavior Genetics*, 24(6), 481–491. doi:10.1007/BF01071561
- Markon, K.E., Krueger, R.F., & Watson, D. (2005). Delineating the structure of normal and abnormal personality: An integrative hierarchical approach. *Journal of Personality and Social Psychology*, 88(1), 139-157.
- McCrae, R. R., Terracciano, A., Firpo, L., Etcheverry, L., Fink, A., & Hohenbichler, C. (2005). Universal features of personality traits from the observer's perspective : Data from 50 cultures. *Journal of Personality and Social Psychology*, 88(3), 547–561. doi:10.1037/0022-3514.88.3.547

- Meier, M. H., Slutske, W. S., Heath, A. C., & Martin, N. G. (2011). Sex differences in the genetic and environmental influences on childhood conduct disorder and adult antisocial behavior. *Journal of Abnormal Psychology, 120*(2), 377–88. doi:10.1037/a0022303
- Miller, J. D., Lynam, D., & Leukefeld, C. (2003). Examining antisocial behavior through the lens of the five factor model of personality. *Aggressive Behavior, 29*(6), 497–514. doi:10.1002/ab.10064
- Neale, M. C., & Cardon, L. R. (1992). *Methodology for Genetic Studies of Twins and Families*. Dordrecht: Kluwer. doi:10.1136/jmg.30.9.800-a
- Oliver, J. P., & Srivastava, S. (1995). The big five trait taxonomy. In L. A. Pervin & O. P. John (Eds.), *Handbook of Personality: Theory and Research* (2nd ed., pp. 102–138). New York: Guilford Press.
- Raftery, A. E. (1995). Bayesian model selection in social research. *Sociological Methodology, 25*, 111-163. doi:10.2307/271063
- Rettew, D. C., Rebollo-Mesa, I., Hudziak, J. J., Willemsen, G., & Boomsma, D. (2008). Non-additive and additive genetic effects on extraversion in 3314 Dutch adolescent twins and their parents. *Behavior Genetics, 38*, 223-233.
- Rettew, D. C., Vink, J. M., Willemsen, G., Doyle, A., Hudziak, J. J., & Boomsma, D. I. (2006). The genetic architecture of neuroticism in 3301 Dutch adolescent twins as a function of age and sex : A study from the Dutch Twin Register. *Twin Research and Human Genetics, 9*, 24–29.
- Riemann, R., Angleitner, A., & Strelau, J. (1997). Genetic and Environmental Influences on Personality: A Study of Twins Reared Together Using the Self- and Peer Report NEO-FFI Scales. *Journal of Personality, 65*, 449-475.

- Schmitt, D. P., Realo, A., Voracek, M., & Allik, J. (2009). "Why can't a man be more like a woman? Sex differences in big five personality traits across 55 cultures": Correction to Schmitt et al. (2008). *Journal of Personality and Social Psychology*, 96(1), 118.
doi:10.1037/a0014651
- Tellegen, A. (1985). *Brief manual for the Multidimensional Personality Questionnaire*.
Unpublished manuscript, University of Minnesota.
- Vecchione, M., Alessandri, G., Barbaranelli, C., & Caprara, G. (2012). Gender differences in the Big Five personality development: A longitudinal investigation from late adolescence to emerging adulthood. *Personality and Individual Differences*, 53(6), 740–746.
doi:10.1016/j.paid.2012.05.033
- Viken, R. J., Rose, R. J., Kaprio, J., & Koskenvuo, M. (1994). A developmental genetic analysis of adult personality: Extraversion and neuroticism from 18 to 59 years of age. *Journal of Personality and Social Psychology*, 66, 722-730.
- Vukasovic, T & Bratko, D. (2015). Heritability of personality: A meta-analysis of behavior genetic studies. *Psychological Bulletin*, 141(4), 769–785.
- Weiss, A., Bates, T. C., & Luciano, M. (2008). Happiness is a personal(ity) thing. *Psychological Science*, 19(3), 205–211.
- Zimprich, D., Allemand, M., & Lachman, M. E. (2012). Factorial structure and age-related psychometrics of the MIDUS personality adjective items across the life span. *Psychological Assessment*, 24(1), 173–186. doi:10.1037/a0025265

Figure Captions

Figure 1. Non-scalar sex limitation model to test for qualitative sex differences in genetic and environmental variance of an observed phenotype, P . Members of each twin pair (Twin 1 and Twin 2) are shown for same sex male pairs (upper left), same-sex female pairs (upper right), and opposite-sex DZ pairs (bottom center). A denotes additive genetic influences, C denotes common environmental influences shared between family members, and E denotes non-shared environmental influences. The correlations between latent genetic factors are set to 1.0 for MZ twins and 0.5 for same-sex DZ twins and the correlation between latent genetic factors for opposite-sex DZ twins (r_g) is freely estimated. Correlations between latent common environmental factors are set to 1.0 for all twins. Total phenotypic variance is calculated by squaring paths a , c , and e and summing them.

Figure 1.

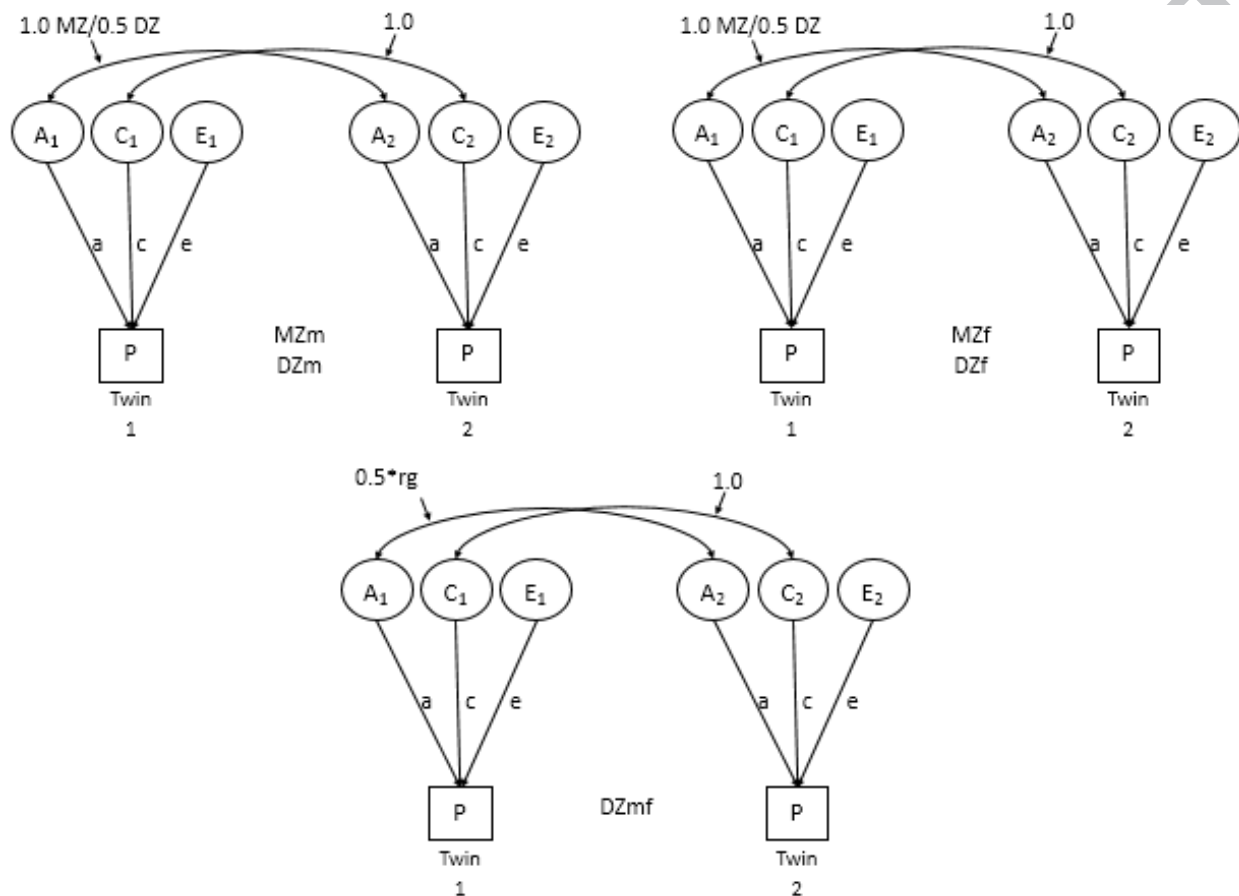

Table 1. Descriptive statistics

BFM Personality Trait		N	Mean (SD)	T-test	Cohen's d
Neuroticism	Men	754	2.19 (0.67)	-3.33**	-0.15
	Women	970	2.29 (0.66)		
Extraversion	Men	754	3.19 (0.57)	-1.84	-0.09
	Women	970	3.24 (0.55)		
Openness	Men	754	2.99 (0.50)	1.66	0.08
	Women	969	2.95 (0.55)		
Agreeableness	Men	754	3.39 (0.50)	-10.78***	-0.52
	Women	971	3.63 (0.41)		
Conscientiousness	Men	755	3.38 (0.42)	-5.38***	-0.26
	Women	970	3.49 (0.43)		

* $p < .05$, ** $p < .01$, *** $p < .001$.

Table 2. Twin Pair Correlations With 95% Confidence Intervals for BFM Domains

BFM Personality Domain	MZ Males	MZ Females	DZ Males	DZ Females	DZ Opposite Sex
Neuroticism	0.54 (0.41 to 0.65)	0.50 (0.38 to 0.60)	0.23 (0.05 to 0.41)	0.26 (0.12 to 0.40)	0.21 (0.07 to 0.34)
Extraversion	0.46 (0.31 to 0.58)	0.43 (0.30 to 0.54)	0.19 (0.00 to 0.36)	0.06 (-0.09 to 0.21)	0.17 (0.03 to 0.30)
Openness	0.41 (0.26 to 0.54)	0.42 (0.29 to 0.54)	0.28 (0.10 to 0.45)	0.22 (0.07 to 0.36)	0.19 (0.05 to 0.32)
Agreeableness	0.32 (0.17 to 0.46)	0.28 (0.13 to 0.41)	-0.01 (-0.20 to 0.18)	0.13 (-0.02 to 0.28)	0.14 (0.00 to 0.27)
Conscientiousness	0.41 (0.26 to 0.54)	0.49 (0.37 to 0.59)	0.20 (0.01 to 0.38)	0.19 (0.04 to 0.33)	0.15 (0.01 to 0.29)

Table 3. Fit statistics for biometric models

Model	-2LL	df	Δ df	Δ -2LL	p	AIC	BIC
Neuroticism							
Non-scalar Sex Limitation	3340.43	1715	-	-	-	-89.57	-8459.43
Scalar Sex Limitation	3341.44	1716	1	1.01	0.31	-90.56	-8465.30
Homogeneity	3341.83	1719	4	1.40	0.84	-96.17	-8485.55
Extraversion							
Non-scalar Sex Limitation	2798.53	1715	-	-	-	-631.47	-9001.33
Scalar Sex Limitation	2804.16	1716	1	5.63	0.02	-627.84	-9002.58
Homogeneity	2802.98	1719	4	4.45	0.35	-635.02	-9024.40
Openness							
Non-scalar Sex Limitation	2600.75	1714	-	-	-	-827.25	-9192.23
Scalar Sex Limitation	2601.12	1715	1	0.37	0.54	-828.88	-9198.74
Homogeneity	2602.23	1718	4	1.48	0.83	-833.77	-9218.27
Agreeableness							
Non-scalar Sex Limitation	2205.89	1716	-	-	-	-1226.1	-9600.85
Scalar Sex Limitation	2205.89	1717	1	0.00	1.00	-1228.1	-9607.73
Homogeneity	2213.95	1720	4	8.07	0.09	-1226.1	-9620.31
Conscientiousness							
Non-scalar Sex Limitation	1900.93	1716	-	-	-	-1531.1	-9905.81
Scalar Sex Limitation	1903.23	1717	1	2.30	0.13	-1530.8	-9910.39
Homogeneity	1905.26	1720	4	4.33	0.36	-1534.7	-9929.01

Table 4. Unstandardized and standardized variance components from homogeneity models.

FFM Personality Domain	Unstandardized Variance Components			Total Variance	Standardized Variance Components		
	A	C	E		A	C	E
Neuroticism	0.15	0.06	0.23	0.43	0.34	0.14	0.53
95% CI	(0.11-0.22)	(0.00-0.11)	(0.20-0.26)	-	(0.19-0.50)	(0.07-0.25)	(0.45-0.61)
Extraversion	0.10	0.02	0.18	0.31	0.33	0.07	0.60
95% CI	(0.05-0.15)	(0.00-0.06)	(0.16-0.21)	-	(0.18-0.48)	(0.00-0.19)	(0.51-0.69)
Openness	0.07	0.04	0.16	0.28	0.27	0.15	0.58
95% CI	(0.00-0.12)	(0.00-0.08)	(0.14-0.19)	-	(0.17-0.42)	(0.04-0.15)	(0.50-0.67)
Agreeableness	0.07	0.01	0.14	0.22	0.31	0.02	0.67
95% CI	(0.04-0.09)	(0.00-0.03)	(0.13-0.17)	-	(0.14-0.42)	(0.00-0.14)	(0.06-0.71)
Conscientiousness	0.07	0.02	0.10	0.19	0.36	0.09	0.55
95% CI	(0.04-0.10)	(0.00-0.04)	(0.08-0.12)	-	(0.19-0.52)	(0.00-0.21)	(0.47-0.64)

Supplementary Table 1. Comparison of ACE, ADE, and AE Models for BFM Domains.

Model	-2LL	df	BIC
Neuroticism			
ACE	3341.85	1719	-8485.53
ADE	3341.74	1719	-8485.64
AE	3341.85	1720	-8492.41
Extraversion			
ACE	2799.09	1719	-9028.29
ADE	2796.29	1719	-9031.09
AE	2799.09	1720	-9035.18
Openness			
ACE	2602.56	1718	-9217.94
ADE	2602.57	1718	-9217.93
AE	2602.57	1719	-9224.81
Agreeableness			
ACE	2215.24	1720	-9619.03
ADE	2212.62	1720	-9621.65
AE	2215.24	1721	-9625.91
Conscientiousness			
ACE	1903.22	1720	-9931.05
ADE	1902.20	1720	-9932.06
AE	1903.22	1721	-9937.93

Highlights

- Mean level sex differences were found for Neuroticism, Agreeableness, and Conscientiousness (women higher on all)
- No evidence of qualitative genetic differences between men and women on any of the Big Five traits
- No evidence of quantitative genetic or environmental differences between men and women on any of the Big Five traits