

The Phenotypic and Genetic Relationships Among Measures of Cognitive Ability, Temperament, and Scholastic Achievement

Stephen A. Petrill^{1,2} and Lee Anne Thompson¹

Received 9 Sept. 1992—Final 18 May 1993

The covariance among measures of cognitive ability, temperament, and scholastic achievement was examined in a subsample of 326 (89 Monozygotic, 74 Dizygotic) twins drawn from the Western Reserve Twin Project. Both phenotypic and behavioral genetic models were fit to the data. Univariate analyses indicate significant genetic influences on cognitive, achievement, and temperament variables. Common environmental influences also affected cognition and achievement but not temperament. Multivariate analyses indicate that both genetic and common environmental influences contribute to the covariance among all three variables. Cognition and achievement are highly genetically correlated. In contrast, achievement and temperament are highly correlated for common environmentality, while cognition and temperament are not.

KEY WORDS: Achievement; cognition; school age; temperament; twins.

INTRODUCTION

In general, behavioral genetic studies have suggested that the covariance between cognitive and scholastic achievement is due almost exclusively to genetic factors (Brooks *et al.*, 1990; Cardon *et al.*, 1990; Thompson *et al.*, 1991). Although the importance of genetic covariance has been widely replicated, it is not known whether the phenotypic relationship between cognition and achievement is direct or mediated by other psychological constructs. Furthermore, only about 25% of the phenotypic variance is shared between cognition and achievement (Brody and Brody, 1976); the majority of the variance in scholastic achievement is independent of cognitive ability.

Temperament may be a potential moderator of scholastic ability. Studying temperament may lead to a better understanding of achievement in two ways: (1) temperament may moderate the relationship between intelligence and school achievement

and (2) temperament may explain differences in achievement independent of intelligence. Individual differences in temperament may be directly related to intelligence and achievement or may indirectly affect these variables through teachers' (and the student's own) perceptions of intellectual and scholastic abilities. Thus, a child's intellectual ability not only affects how much the individual can benefit from an academic environment, but also affects the environment which the teacher supplies to the student. Similarly, differences in temperament may lead to differential opportunities for academic attainment, whether through the child's own actions or through a teacher's response to different behavioral styles.

However, Plomin and Bergeman (1991) have shown that environmental measures are not pure indicators of the environment, but display genetic components. According to these researchers, genetic variation leads to measurable behavioral differences which, in turn, lead to differential environmental experiences. Consequently, the unequal application of the academic environment may be moderated through differences in students' geno-

¹ Department of Psychology, Case Western Reserve University, Cleveland, Ohio 44106.

² To whom correspondence should be addressed.

types. Specifically, differential application of the school environment not only may be a function of genetic variation associated with intelligence, but also may be related to genetic variance underlying individual differences in temperament.

Before this larger issue of understanding genotype-environment correlations can be adequately studied, the relationships among temperament, cognition, and achievement must be better understood. Not only must the phenotypic (or directly measurable) relationship among these variables be assessed, but the genetic and environmental covariance among these variables must be quantified.

Although the three domains have not been fully integrated, many studies have examined both the relationship between temperament and cognition and the covariance between measures of temperament and achievement. Results have been inconclusive concerning the phenotypic relationship between measures of temperament and cognitive ability. Matheny (1989) reported correlations ranging from .2 to .4 between measures of temperament and cognition in a sample ranging in age from infancy to 12 years. Research by Lamb and his colleagues found links between sociability and cognitive ability (Stevenson and Lamb, 1979; Lamb *et al.*, 1981; Lamb, 1982) as well as between extraversion and cognitive ability (Lamb *et al.*, 1981). Thomas and Chess (1977) failed to find a relationship between temperament and cognition. However, the factor structure of Thomas and Chess' measures of temperament has been questioned (Buss and Plomin, 1975, 1984), and it is possible that their dimensions of temperament may be excluding sources of variance important to the phenotypic relationship between temperament and cognition.

Despite the many studies examining the phenotypic relationship between temperament and cognition, very few behavioral genetic studies have been conducted. Although Thompson *et al.* (1988) conducted multivariate analyses upon measures of temperament and cognition in infants, school-age populations have been virtually ignored.

Researchers have also found inconclusive results for temperament and school achievement. Lerner *et al.* (1983) reported that a child's temperament is related to both teachers' judgments of academic attributes and the child's actual scores on achievement tests. The phenotypic correlation between temperament and achievement ranged from .20 to .24, depending upon the specific measures employed—roughly the same magnitude as the rela-

tionship between temperament and cognition. Similarly, Martin and Holbrook (1985) found that temperament, as rated by teachers, and school achievement correlated about .4. In contrast, Thomas and Chess (1977) found consistent relationships between temperament and school achievement only at the low end of achievement. Significant relationships were found at other levels of ability, but they were widely scattered. Comprehensive, multivariate genetic analyses of the interrelationship between temperament and achievement have not been conducted.

Even fewer studies have examined the triarchic relationship among cognition, achievement, and temperament. Mevarech (1985) conducted a study simultaneously analyzing measures of cognition, temperament, and achievement. In a phenotypic analysis of grade-school children, Mevarech found significant correlations between temperament and cognition ($r = .28-.32$), temperament and achievement ($r = .31-.54$), and cognition and achievement ($r = .45-.51$). However, no behavior genetics analyses were conducted.

In sum, phenotypic relationships have been found among measures of cognitive ability, temperament, and school achievement. Although behavior genetic studies have established the importance of heritable components in all three domains, only the relationship between cognition and achievement has been subjected to rigorous genetic analysis in school-age populations.

Thus, the current study explores the triarchic relationship among temperament, cognitive ability, and school achievement. The pattern and magnitude of the phenotypic relationships are assessed first. Then the genetic and environmental contributions at the univariate and multivariate levels are estimated. Quantifying these relationships not only will provide insight into the differential etiology of each variable, but also will describe the importance of genetics and environment to the phenotypic covariance among cognitive ability, temperament, and school achievement.

METHOD

Subjects

The current study [89 monozygotic (MZ), 74 dizygotic (DZ) pairs] examines a subsample of the Western Reserve Twin Project (WRTP). The mean WISC-R IQ was 107.01 ($SD = 15.10$). All sub-

jects participating in the WRTP were recruited through state birth records provided by the Ohio State Bureau of Vital Statistics and school nominations. Those subjects in the current study responded to a questionnaire which was mailed to all subjects who participated in the original WRTP study. The response rate was 58%. Thus, data were collected at two time points. At time 1 twins were given a battery of cognitive and achievement tests as part of the WRTP. At time 2 the twins' temperament was assessed through a follow-up questionnaire. Analyses were conducted upon the same set of 163 twin pairs at both time points. At time 1, the twins ranged from 6 to 13 years ($X = 9.51$, $SD = 1.75$). At time 2, the same twins ranged from 7 to 15 years ($X = 11.47$, $SD = 2.01$). All subjects lived in a six-county area surrounding Greater Cleveland. Zygosity was assessed by a standardized test which measured physical similarity (Nichols and Bilbro, 1966). If results of this test were uncertain, blood samples were sent to the Minneapolis Memorial Blood Bank for analysis.

Tests

All twins in the full WRTP sample were given a battery of intelligence and achievement tests across three sessions. The first session (1–1.5 h) was administered in the twins' home. The second session (2–4 h) and third session (1–1.5 h) were conducted in the Psychology Department at Case Western Reserve University in Cleveland, Ohio. Twins were also given tests measuring basic physical attributes. In the current study, WRTP measures employed were (1) the subtest and factor scale scores of the Wechsler Intelligence Scale for Children—Revised (WISC-R; Wechsler, 1974), (2) the Colorado Test of Specific Cognitive Abilities (SCA; Cyphers *et al.*, 1989), (3) the Metropolitan Achievement Test (MAT; Prescott *et al.*, 1986), and (4) the Cognitive Abilities Test (CAT; Detterman, 1988), a computer-administered battery measuring elementary cognitive abilities.

In addition to the tests given as part of the WRTP, the Colorado Childhood Temperament Inventory (CCTI; Rowe and Plomin, 1977) was sent to all who participated in the WRTP. The CCTI is a 30-item battery which divides temperament into six scales—emotionality, activity, sociability, attentiveness, soothability, and reaction to foods. This questionnaire was completed by one parent for each child in the current study.

The measures described above were summarized through the use of factor analysis. The SCA scales, WISC-R subtests, and CAT variables were analyzed simultaneously to provide a general intelligence factor. The achievement factor was formed from the MAT subtests and a temperament factor from the six scales (Emotionality, Activity, Sociability, Attentiveness, Soothability, and Reaction to Foods) comprising the CCTI.

Statistical Procedures

Several statistical methods were employed to study the genetic and environmental covariance underlying measures of cognition, temperament, and achievement. First, exploratory and confirmatory factor analyses were used to form cognitive, achievement, and temperament factors. Next the phenotypic relationships among temperament, cognition, and achievement were assessed by analyzing the Pearson and partial correlations among the cognitive, achievement, and temperament factors. The genetic and environmental variance underlying individual differences within each domain was then estimated using structural equation modeling procedures (see Neale and Cardon, 1992). After establishing phenotypic relationships among the variables and quantifying the genetic and environmental variance within each construct, multivariate structural equation modeling procedures (Neale and Cardon, 1992) were conducted to test the extent to which temperament, cognition, and achievement may be explained by common genetic and environmental parameters. Finally, genetic and environmental correlations were calculated based upon the estimates obtained in the multivariate analyses.

RESULTS

Formulation of the Factors

The first unrotated principal components were formed for intelligence (GFAC), temperament (CCTIFAC), and achievement (ACHFAC) variables (Eigen = 7.96, 1.87, and 5.76, respectively). With respect to intelligence and achievement, exploratory factor analyses were conducted across the full WRTP twin sample. Cases who participated in the current study were then selected for further analyses. Because only the subjects participating in the current study possessed temperament data, the factor analysis of temperament was confined to the

follow-up sample. However, as stated earlier, intelligence and achievement factor scores were calculated based upon the entire WRTP sample. Thus, the potential effects of ascertainment bias were assessed. Using confirmatory analysis, it was possible to fit the parameter estimates from the full WRTP sample to a covariance matrix calculated from the cases corresponding to the current, follow-up sample (TLI = .92, PTLI = .65) [see Marsh *et al.* (1988) and Mulaik *et al.* (1989) for an explanation of the Tucker-Lewis goodness-of-fit index]. In all cases, variables of study were composed of factor scores.

Phenotypic Analyses

The phenotypic relationship among the "g" factor, the temperament factor, and the achievement factor were then studied. Table I displays both full and partial correlations among the three domains. In the full correlations, the achievement and cognitive factors were moderately correlated. The temperament factor was also correlated with the cognitive and achievement factors, but to a lesser degree. Partial correlations were then calculated to examine the independent relationships among temperament, cognition, and achievement factors. The partial correlations between achievement and cognition and achievement and temperament were of relatively the same magnitude as the full correlations. However, the partial correlation between temperament and cognition was essentially zero.

Univariate Genetic Analyses

Twin analyses were conducted using LISREL VII (Joreskog and Sorbom, 1989) to explore the

Table I. Full and Partial Correlations Among Achievement, Cognition, and Temperament Factors^a

	ACHFAC	COGFAC	CCTIFAC
Full			
ACHFAC	1.00		
GFAC	.46*	1.00	
CCTIFAC	.25*	.14*	1.00
Partial			
ACHFAC	1.00		
GFAC	.45*	1.00	
CCTIFAC	.21*	.02	1.00

^a $N = 326$.

* $p < .001$.

genetic and environmental variance underlying the factor scores. Table II lists the results for the univariate genetic models. Four models were fit to each factor estimating: (1) specific environment (E), (2) specific and common environment (EC), (3) specific environment and additive genetic (EH), and (4) specific environment, common environment, and additive genetic (ECH) parameters. The best-fitting model was assessed by examining (1) the goodness of fit of each model and (2) the relative differences in chi-square across the four competing models. According to these criteria, the ECH model best fit the GFAC data ($\chi^2 = 2.46$, $df = 3$, $p = .48$). The ECH model provided a significant improvement in fit over the next best-fitting (EH) model ($\chi^2_{\text{change}} = 4.75$, $df_{\text{change}} = 1$, $p < .05$). After squaring the standardized path coefficients obtained in the ECH model, parameter estimates for GFAC were as follows: $h^2 = .46$, $c^2 = .37$, and $e^2 = .16$. With respect to CCTIFAC, both the EH and the ECH models provided a significant improvement in fit over the EC model. However, given that the common environmental parameter could not be identified, the EH model provided the best estimation of twin covariance ($\chi^2 = 4.71$, $df = 4$, $p = .32$; $\chi^2_{\text{change}} = 14.03$, $df_{\text{change}} = 1$, $p < .05$). This model yielded an $h^2 = .67$ and $e^2 = .32$. An ECH model best fit ACHFAC ($\chi^2 = 3.10$, $df = 3$, $p = .38$; $\chi^2_{\text{change}} = 27.42$, $df_{\text{change}} = 1$, $p < .05$). Parameter estimates were as follows: $h^2 = .27$, $c^2 = .67$, and $e^2 = .06$.

Table II. Univariate Genetic Models: Cognitive, Temperament, and Achievement Factors^a

Model	e^2	c^2	h^2	χ^2	df	p
GFAC (Cognition)						
E	1.00			148.78	5	.000
EC	.26	.74		18.90	4	.001
EH	.16		.85	7.21	4	.125
ECH	.16	.37	.46	2.46	3	.480
CCTIFAC (Temperament)						
E	1.00			69.76	5	.000
EC	.49	.50		18.74	4	.001
EH	.32		.67	4.71	4	.318
ECH	.32	.00	.67	4.71	3	.194
ACHFAC (Achievement)						
E	1.00			274.97	5	.000
EC	.12	.88		33.07	4	.000
EH	.06		.94	30.52	4	.001
ECH	.06	.67	.27	3.10	3	.376

^a $N(\text{MZ}) = 89$; $N(\text{DZ}) = 74$.

Multivariate Genetic Analyses

Multivariate genetic analyses were also conducted using LISREL VII. A model was fit to the data in which general additive genetic, common environmental, and specific environmental factors influence each variable. In addition, specific additive genetic, common environmental, and specific environmental parameters influence each variable (see Fig. 1). The full model yielded a $\chi^2 = 31.14$, $df = 24$, and $p = .150$.

After fitting the full model to the data, two alternate models were fit to test the importance of genetic and shared environmental variance. In model 1 all genetic parameters were set to zero. In model 2, all shared environmental parameters were set to zero. In each case, not only did both models fail to fit the data, but a significant decrease in fit from

the full model resulted. Dropping the genetic parameters yielded a $\chi^2 = 79.16$, $df = 30$, and $p < .05$ ($\chi^2_{\text{change}} = 48.02$, $df_{\text{change}} = 6$, $p < .05$). Setting the shared environmental parameters to zero yielded a $\chi^2 = 87.52$, $df = 30$, $p < .05$ ($\chi^2_{\text{change}} = 56.38$, $df_{\text{change}} = 6$, $p < .05$).

Because several parameters did not achieve empirical identification (Bollen, 1989) in the full model, the significance of the nonzero parameter estimates could not be calculated. Consequently, the general nonshared environmental parameter and the specific shared environmental parameter in the temperament factor, and the specific nonshared environmental, genetic, and shared environmental parameters in the achievement factor were dropped. This model yielded a $\chi^2 = 31.27$, $df = 29$, and $p = .35$ ($\chi^2_{\text{change}} = .13$, $df_{\text{change}} = 5$, $p > .05$) (see Fig. 2). All parameter estimates were significant

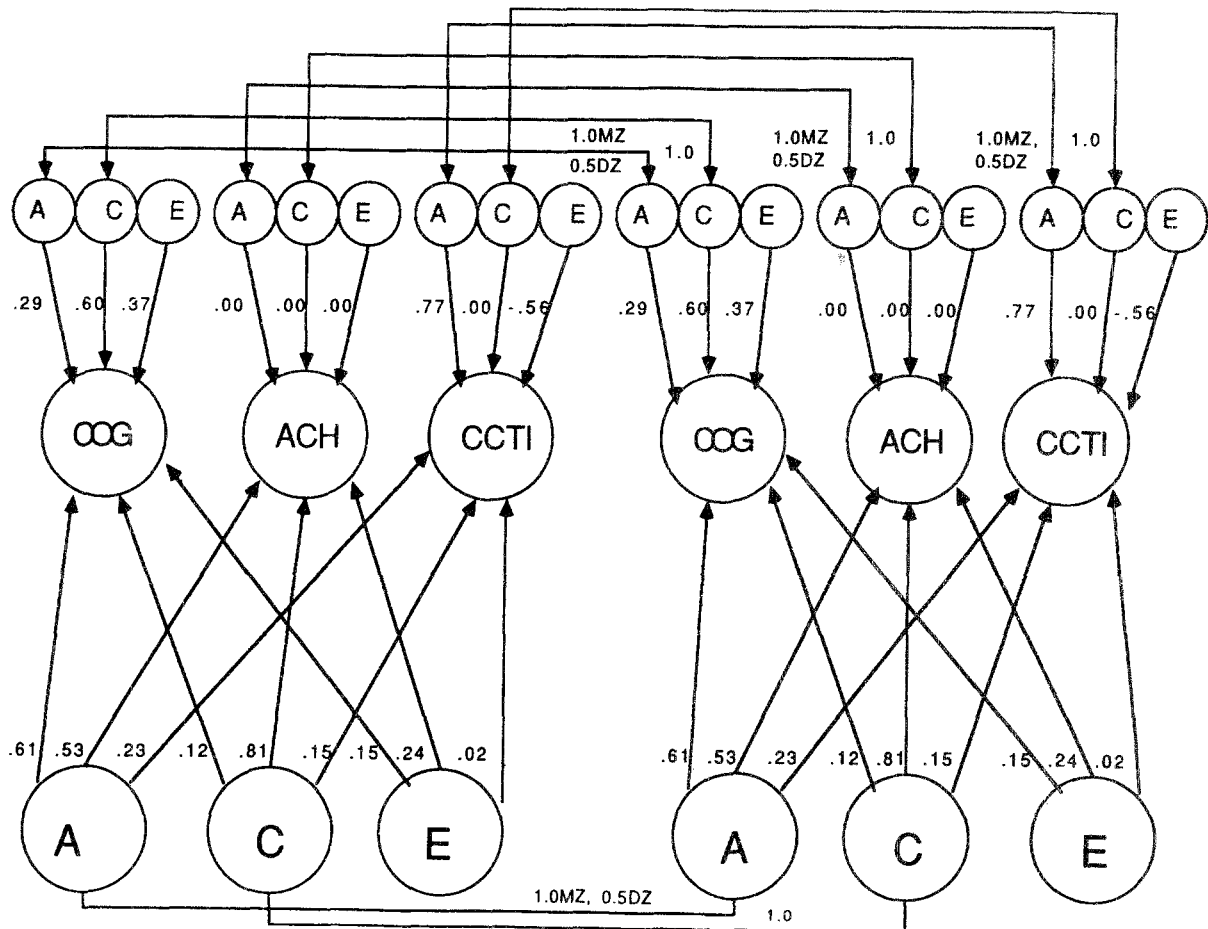

Fig. 1. Path diagram: full model.

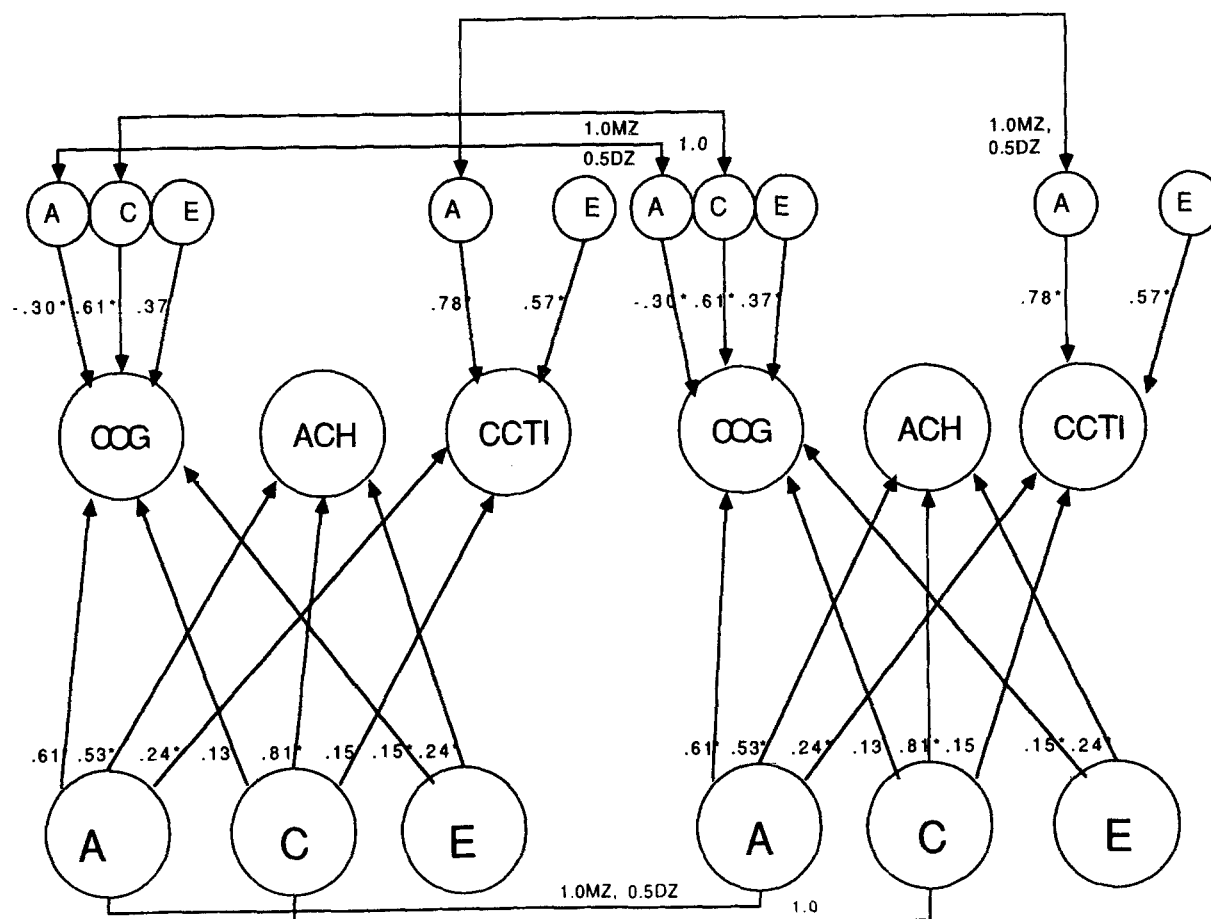

Fig. 2. Path diagram: reduced model.

with the exception of the general shared environmental parameters influencing the cognition and temperament factors. Dropping these parameters did not yield a significant change in chi-square from the full model ($\chi^2 = 34.87$, $df = 31$, $p = .283$; $\chi^2_{\text{change}} = 3.73$, $df_{\text{change}} = 7$, $p > .05$).

Univariate estimates of h^2 , c^2 , and e^2 were calculated from the full multivariate model. Table III presents these data. The results compare favorably with the estimates obtained using univariate modeling procedures.

Given that the covariance among the cognitive, temperament, and achievement factors may be explained by shared genetic and environmental influences, the parameter estimates from the full model were used to calculate genetic and common environmental correlations (Neale and Cardon, 1992). With respect to genetic correlations, the cognitive and achievement factors were highly correlated (.92),

Table III. Univariate Estimates of h^2 , c^2 , and e^2 from Full Multivariate Model: Cognitive, Temperament, and Achievement Principal Components^a

Factor	h^2	c^2	e^2
GFAC	.46	.38	.16
CCTIFAC	.66	.02	.32
ACHFAC	.28	.66	.06

^a $N(\text{MZ}) = 89$; $N(\text{DZ}) = 74$.

while the correlations between temperament and cognition and temperament and achievement were smaller (.26 and .24, respectively). In contrast, the common environmental correlation between achievement and temperament was high (1.0), while the correlations between cognition and achievement and cognition and temperament were of a low magnitude (.16 and .16, respectively).

DISCUSSION

Results of this study suggest that temperament, cognition, and achievement share phenotypic variance which is supported by both genetic and common environmental factors. Cognitive ability and school achievement share approximately five times more variance than either temperament and achievement or temperament and cognition. Partial correlations suggest that a direct relationship exists between temperament and achievement as well between cognition and achievement. However, the relationship between cognition and temperament disappears when the effects of achievement are controlled. Furthermore, behavioral genetic models indicate that genetic effects are the primary source of variance underlying the phenotypic correlation between cognition and achievement. The correlation between temperament and achievement is mediated primarily by common environmental factors, while the relationship between temperament and cognition is affected by both genetic and common environmental factors. Thus, not only does temperament share differential amounts of phenotypic variance with both cognition and achievement, but also the genetic architecture underlying these relationships differs. Common environmental effects overlap completely in the relationship between temperament and achievement, while both genetics and environment affect the covariation between temperament and cognition.

Despite a high common environmental covariance with achievement and moderate genetic and shared environmental correlations with cognition, temperament shares little phenotypic covariance with these variables. After partialling out the effects of temperament, the phenotypic correlation between cognition and achievement remains basically unchanged (.45). Although temperament is statistically related to cognition and achievement, it does not explain a great deal of the relationship between cognition and achievement. Intuitively, many educators believe that temperament plays an important mediating role in the expression of ability on achievement. The current results do not strongly support this idea, possibly because (1) measures of temperament were collected 2 years after the cognitive and achievement data and (2) our results may be reflective of the broad definition of temperament characteristics inherent in Buss and Plomin's (1975) theory and hence in our measurement of temperament (CCTI). A study exploring specific aspects of

temperament thought to be important for scholastic success simultaneously with measures of cognition and achievement may yield a stronger pattern of results.

ACKNOWLEDGMENTS

This work was supported by NICHD Grant HD21947 awarded to D. K. Detterman and L. A. Thompson and NICHD Training Grant HD07176.

REFERENCES

- Bollen, K. A. (1989). *Structural Equations with Latent Variables*, Wiley, New York.
- Brody, E. B., and Brody, N. (1976). *Intelligence: Nature, Determinants, and Consequences*, Academic Press, New York.
- Brooks, A., Fulker, D. W., and Defries, J. C. (1990). Reading performance and general cognitive ability: A multivariate genetic analysis of twin data. *Personal. Individ. Diff.* 11(2):141-146.
- Buss, A. H., and Plomin, R. (1975). *A Temperament Theory of Personality Development*, Wiley, New York.
- Buss, A. H., and Plomin, R. (1984). *Temperament: Early Developing Personality Traits*, Lawrence Erlbaum, Hillsdale, NJ.
- Cardon, L. R., DiLalla, L. F., Plomin, R., Defries, J. C., and Fulker, D. W. (1990). Genetic correlations between reading performance and IQ in the Colorado Adoption Project. *Intelligence* 14:245-257.
- Cyphers, L., Fulker, D. W., Plomin, R., and DeFries, J. C. (1989). Cognitive abilities in the early school years: No effects of shared environment between parents and offspring. *Intelligence* 13:369-384.
- Detterman, D. K. (1988). CAT: Computerized abilities test for research and teaching. *MicroPsych Network* 4(3):51-62.
- Joreskog, K. G., and Sorbom, D. (1989). *Lisrel 7: A Guide to the Program and Applications*, 2nd ed., SPSS, Inc., Chicago.
- Lamb, M. E. (1982). Individual differences in infant sociability: Their origins and implications for cognitive development. *Adv. Child Dev. Behav.* 16:213-241.
- Lamb, M. E., Garn, S. M., and Keating, M. T. (1981). Correlations between sociability and cognitive performance among eight-month-olds. *Child Dev.* 52:711-713.
- Lerner, J. V., Lerner, R. M., and Zabski, S. (1983). Temperament and elementary school children's actual and rated academic performance: A test of a "goodness-of-fit" model. *Child Psychol. Psychiat.* 26(1):125-136.
- Lerner, R. M., Lerner, J. V., Windle, M., Hooker, K., Lerner, K., and East, P. L. (1986). Children and adolescents in their contexts: Tests of a goodness of fit model. In Plomin, R., and Dunn, J. (eds.), *The Study of Temperament: Changes, Continuities, and Challenges*, Lawrence Erlbaum, Hillsdale, NJ, pp. 99-114.
- Marsh, H. W., Balla, J. R., and McDonald, R. P. (1988). Goodness of fit indexes in confirmatory factor analysis: The effect of sample sizes. *Psychol. Bull.* 103:391-410.
- Martin, R. P., and Holbrook, J. (1985). Relationship of temperament characteristics to the academic achievement of first grade children. *Psychoeduc. Assess.* 3:131-140.
- Matheny, A. P. (1989). Temperament and cognition: Relations between temperament and mental test scores. In Kohn-

- stamm, G. A., Bates, J. E., and Rothbart, M. K. (eds.), *Temperament in Childhood*, Wiley, New York, pp. 263–282.
- Mevarech, Z. R. (1985). The relationships between temperament characteristics, intelligence, task-engagement, and mathematics achievement. *Behav. J. Educ. Psychol.* **55**:156–163.
- Mulaik, S. A., James, L. R., Alstine, J. V., Bennett, N., Lind, S., and Stillwell, C. D. (1989). Evaluation of goodness-of-fit indices for structural equation models. *Psychol. Bull.* **105**:430–445.
- Neale, M. C., and Cardon, L. R. (1992). *Methodology for Genetic Studies of Twins and Families*, Kluwer Academic, Dordrecht.
- Nichols, R. C., and Bilbro, W. C. (1966). The diagnosis of twin zygosity. *Acta Genet.* **16**:265–275.
- Plomin, R., and Bergeman, C. S. (1991). The nature of nurture: Genetic influences on “environmental” measures. *Behav. Brain Sci.* **14**:373–437.
- Prescott, G. A., Balow, I. H., Hogan, T. P., and Farr, R. C. (1986). *Metropolitan Achievement Tests: MAT6*, The Psychological Corporation, New York.
- Rowe, D. C., and Plomin, R. (1977). Temperament in early childhood. *J. Personal. Assess.* **41**:150–156.
- Stevenson, M. B., and Lamb, M. E. (1979). Effects of infant sociability and the caretaking environment on infant cognitive performance. *Child Dev.* **50**:340–349.
- Thomas, A., and Chess, S. (1977). *Temperament and Development*, Brunner/Mazel, New York.
- Thompson, L. A., Fulker, D. W., DeFries, J. C., and Plomin, R. (1988). Multivariate analysis of cognitive and temperament measures in 24-month-old adoptive and nonadoptive sibling pairs. *Personal. Individ. Diff.* **9**(1):95–100.
- Thompson, L. A., Detterman, D. K., and Plomin, R. (1991). Associations between cognitive abilities and scholastic achievement: Genetic overlap but environmental differences. *Psychol. Sci.* **2**(3):158–165.
- Wechsler, D. (1974). *Manual for the Wechsler Intelligence Scale for Children—Revised*, The Psychological Corporation, New York.

Edited by Joanne Meyer