

BRIEF REPORT

A Conceptual Replication of Emotional Intelligence as a Second-Stratum Factor of Intelligence

Thomas Rhys Evans
Coventry UniversityDavid J. Hughes
University of ManchesterGail Steptoe-Warren
Coventry University

MacCann, Joseph, Newman, and Roberts (2014) explored various unidimensional, oblique, hierarchical and bifactor models to suggest that ability EI can represent a distinct set of cognitive abilities that can be placed within existing intelligence frameworks. The current study presents a conceptual replication of these analyses from data collected using alternative (nonproprietary) measures. Using a data set of 830 individuals, the current study provides further evidence to suggest ability EI best represents a hierarchical construct formed of emotion perception, understanding and management factors, structured as a second stratum factor within broader models of cognitive ability.

Keywords: emotional intelligence, Mayer-Salovey-Caruso Emotional Intelligence Test (MSCEIT), Cattell-Horn-Carroll (CHC) theory, structural equation modeling (SEM), confirmatory factor analysis (CFA)

Supplemental materials: <http://dx.doi.org/10.1037/emo0000569.supp>

Emotional intelligence (EI) is a label assigned to a wide array of affect-related individual differences, which, over the past 20 years, have been widely adopted by scholarly researchers and practitioners (Hughes & Evans, 2018). Adopting a cognitive ability perspective, Mayer, Roberts, and Barsade (2008) defined EI as “the ability to carry out accurate reasoning focused on emotions and the ability to use emotions and emotional knowledge to enhance thought” (p. 511). This approach is commonly referred to as “ability EI” to differentiate itself from other EI perspectives and has been refined to represent the cognitive abilities underpinning the perception, understanding, and management of emotion (Fan, Jackson, Yang, Tang, & Zhang, 2010).

The status of ability EI as a type of intelligence has been contested, however its theoretical context is important to a number of recent theoretical models such as the IMAID (Hughes & Evans, 2018) which seek to integrate EI with existing individual differ-

ence frameworks. Definitional, correlational and developmental criteria have been devised and tested to determine whether ability EI can be considered an intelligence type, with broadly supportive results (e.g., Mayer, Caruso, & Salovey, 1999). There is growing evidence to suggest that ability EI can represent a distinct set of cognitive abilities, not simply affective domains of existing abilities, that can be placed within existing intelligence frameworks (Bowman, Markham, & Roberts, 2002; Mayer, Salovey, Caruso, & Sitarenios, 2001). For example, MacCann (2010) adopted non-proprietary measures to differentiate ability EI from fluid and crystallized intelligence; however, there has been little testing of a priori theoretical models (MacCann, Joseph, Newman, & Roberts, 2014).

The most robust investigation of the standing of ability EI within intelligence frameworks comes from MacCann et al. (2014) whom tested various unidimensional, oblique, hierarchical and bifactor models using questionnaire data collected from 688 students. Their data best fit the model in which ability EI, loaded by perception, understanding and management factors, was hierarchically structured under a general intelligence factor alongside broad ability domains such as quantitative reasoning, fluid intelligence, crystallized intelligence, and visual-spatial ability. It was summarized that ability EI could therefore be best understood as a second-stratum ability within the Cattell-Horn-Carroll (CHC) theory of intelligence (McGrew, 2009), with a similar standing to that of these other cognitive abilities (MacCann et al., 2014).

This article was published Online First February 7, 2019.

Thomas Rhys Evans, School of Psychological, Social and Behavioural Sciences, Coventry University; David J. Hughes, Alliance Manchester Business School, University of Manchester; Gail Steptoe-Warren, School of Psychological, Social and Behavioural Sciences, Coventry University.

Correspondence concerning this article should be addressed to Thomas Rhys Evans, School of Psychological, Social and Behavioural Sciences, Coventry University, Coventry, United Kingdom CV1 5FB. E-mail: ab6443@coventry.ac.uk

MacCann et al. (2014) used the Mayer-Salovey-Caruso Emotional Intelligence Test to capture ability EI (MSCEIT; Mayer, Salovey, Caruso, & Sitarenios, 2003), which is one of the most well-known EI tools (Fiori et al., 2014). There are so few alternative measures of ability EI, that the measure and model are often considered analogous (Fiori et al., 2014). Overreliance on this one measure is problematic however, as it is difficult to differentiate test effects from construct effects (MacCann & Roberts, 2008). Furthermore, the MSCEIT has been critiqued for a number of reasons (Mayer et al., 2003), including its proprietary status, factor structure, internal reliability, and validity of individual subscales (Fan et al., 2010; Palmer, Gignac, Manocha, & Stough, 2005). Concerns have also been raised regarding the extent to which the MSCEIT can differentiate individuals with moderate or high levels of ability EI (Fiori et al., 2014), and the implications of a consensus-based scoring method that captures emotional conformity and measurement error (Legree, Pstotka, Tremble, & Bourne, 2005; Maul, 2012).

Based upon the problematic status of the MSCEIT and the psychometric properties of the data it produces, the current study presents a conceptual replication of the MacCann et al. (2014) analyses from data collected using alternative nonproprietary measures. Using a data set of 830 individuals, the current study aims to determine whether previous findings represent MSCEIT test effects, or whether conclusions surrounding the second-stratum structure of ability EI within the CHC model can be considered robust.

Method

Participants

To meet the most conservative rule-of-thumb estimates (i.e. 10 participants per indicator), 620 participants were sought (Bentler & Chou, 1987; Nunnally, 1967). Five-hundred and 27 participants were convenience sampled through Qualtrics. A further 303 participants were recruited through a University research participation scheme and through convenience sampling of social network contacts. In total, 830 individuals (556 females) participated, with 44% aged between 18 and 30, 25% aged between 31 and 45, 31% aged between 46 and 70, and four participants that were 71 years old or older. There was no missing data.

Procedure

Ethical approval was gained from Coventry University Health and Life Sciences Ethics Board. All participants, regardless of

recruitment method, completed the study online, either through Bristol Online Survey or Qualtrics. Participants were provided a participation information sheet then completed the consent form and battery of questionnaires before being debriefed. Participation was part of a larger questionnaire which also featured measures of personality and emotion regulation, and typically took around 60 min to complete.

Materials

Fluid intelligence. Fluid intelligence was measured by the ICAR 9-item Letter and Number Series task (Condon & Revelle, 2014). Participants answer with one of eight answers. Cronbach's Alpha was calculated at .83.

Crystallized intelligence. Crystallized intelligence was assessed by the ICAR 16-item verbal reasoning task whereby participants picked one of eight answers. A Cronbach's Alpha of .81 was calculated.

Emotion perception. Emotion perception was captured by the Ant-Colony Optimized Reading Mind in the Eyes Test (Baron-Cohen, Wheelwright, Hill, Raste, & Plumb, 2001; Olderbak et al., 2015). Ten images of eyes were presented and participants chose from 4 options each to identify the emotion being experienced. Unlike the original measure, this optimized-version is appropriate because it has acceptable internal reliability, and still moderately correlates with emotional perception as captured by The DANVA 2 Faces subscale (Nowicki & Duke, 1994). The Cronbach's Alpha was slightly less than desirable at .59.

Emotion management. Emotion management was measured by the Situational Test of Emotion Management Short Form (Allen, Rahman, Weissman, MacCann, & Roberts, 2015). The data had a Cronbach's Alpha of .65 and involved 18 Situational Judgment Test items answered by one of four options, scored according to expert mean ratings (MacCann & Roberts, 2008).

Emotion understanding. Emotion understanding was assessed by the Situational Test of Emotion Understanding Brief, with a 19-item Situational Judgment Test format, five response options and a Cronbach's Alpha of .74.

Results

Reliability, Descriptive Statistics, and Correlations Between Variables

Reliability and descriptive statistics for all measures are shown in Table 1. Cronbach's Alpha estimates were marginal for Emotion

Table 1
Reliability, Descriptive Statistics, and Correlations for All Measures

Variable	Mean (SD)	1	2	3	4	5
1. Fluid Intelligence	4.43 (2.79)	(.83)				
2. Crystallized Intelligence	9.26 (3.65)		.61*			
3. Emotion Perception	7.31 (2.04)		(.81)	.28*		
4. Emotion Understanding	10.08 (2.70)			.39*	.43*	
5. Emotion Management	10.87 (3.14)				(.65)	.60*

Note. Cronbach's Alpha italicized and reported along the diagonal.

* $p < .01$.

Perception and Emotion Understanding but were acceptable for all other measures. Pearson correlations among the cognitive ability and ability EI scores are shown in Table 1. This matrix demonstrates positive manifold: correlations between all scales are positive. Concurrent with MacCann et al. (2014), correlations among ability EI markers tend to be higher (average $r = .50$) than correlations between the ability EI and general cognitive ability markers (average $r = .38$).

Structural Models

In accordance with the original analyses conducted by MacCann et al. (2014), eight a priori models were tested (See Figure 1). First, three models using just the ability EI data explored: a unidimensional model (Model 1); a hierarchical model where Perception, Understanding, and Management factors loaded onto a second-order ability EI factor (Model 2); and a bifactor model of ability EI where each indicator loaded onto both a general ability EI factor as well as their specific subfactor (Model 3). Second, five models using all data explored: a unidimensional model where all ability EI and cognitive ability markers loaded onto a g factor (Model 4); an oblique five-factor model where five factors of Perception, Understanding, Management, Gf, and Gc correlate freely (Model 5); a hierarchical five-factor model where the five factors from Model 4 define an overall g factor (Model 6); a hierarchical model with ability EI as a second-stratum ability, such that a second-order ability EI factor is defined by Perception, Understanding, and Manage-

ment factors, and a higher-order g factor is defined by Gf, Gc, and the ability EI factor (Model 7); and a bifactor model where each indicator defined both a g factor and one of the five broad group factors described in Model 5 (Model 8; See MacCann, Joseph, Newman, & Roberts 2014).

All models were run using MPlus 6.0 and the Weighted Least Squares Means and Variances (WLSMV) estimator, which was considered most appropriate for the categorical and Likert-type data collected as it makes no assumptions regarding distribution or levels of measurement (Browne, 1984; Muthén & Muthén, 2010). Consistent with MacCann et al. (2014) and the recommendations of general simulation data (e.g., Hu & Bentler, 1999), we consider the CFI, TLI, and RMSEA when evaluating model fit. Because the SRMR is not produced with WLSMV estimation we were unable to report this statistic. Fit was considered adequate with values of $\leq .08$ for the RMSEA (Browne & Cudeck, 1993) and $\geq .90$ for the CFI and TLI (Bentler & Bonett, 1980) with values above .95 preferred (Hu & Bentler, 1999). Chi-square is extremely sensitive to sample size and so while presented, is not used for evaluation of model fit. Similarly, WRMR is an experimental fit statistic, and thus while included for completeness, is not used to evaluate model fit (Muthén & Muthén, 2010). See Supplementary Materials for all model matrices.

Model 1: A unidimensional model of the ability EI test items did not show good fit ($\chi^2[1034, N = 830] = 1273.29, p < .001$; RMSEA = .017; CFI = .891; TLI = .886; WRMR = .900). The average item loading was .36, ranging from $-.24$ to .80.

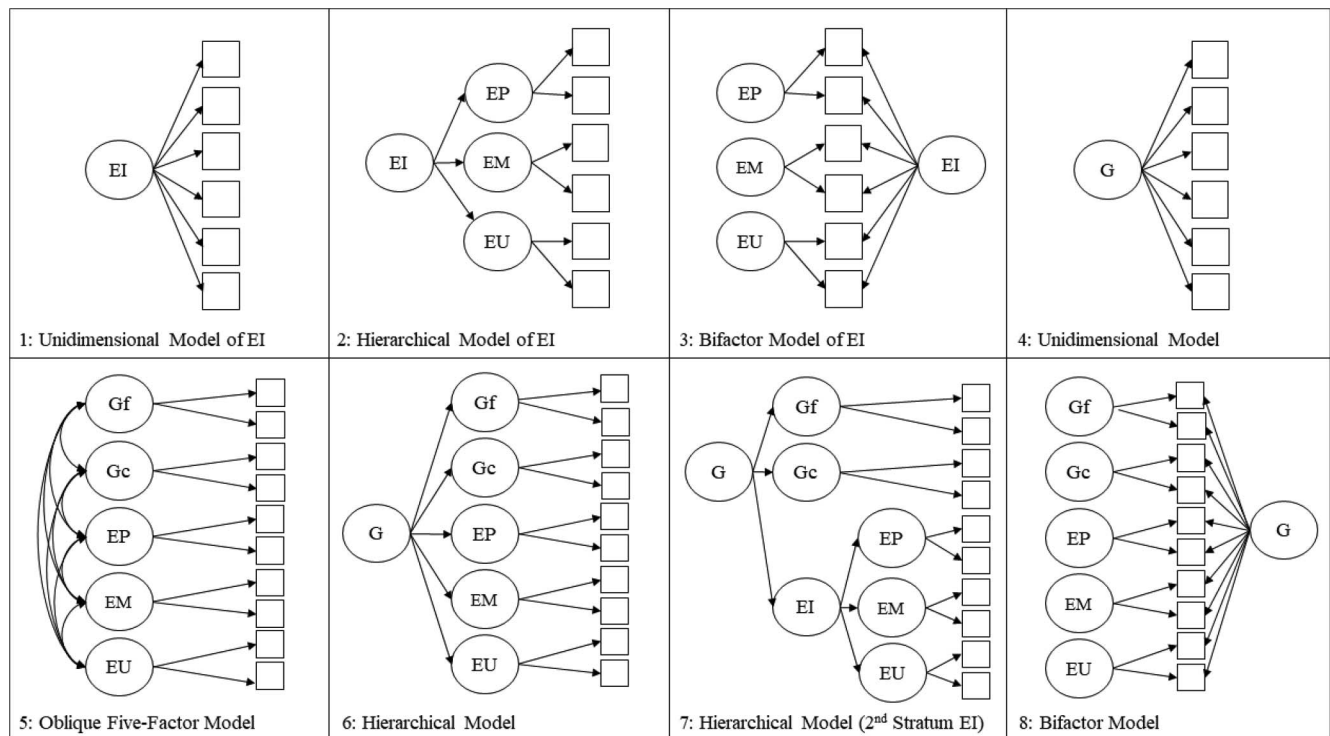

Figure 1. Simplified illustrations of the eight models tested; G = intelligence; Gf = fluid intelligence; Gc = crystallized intelligence; EP = Emotion Perception; EU = Emotion Understanding; EM = Emotion Management.

Model 2: After fixing the factor variance of Emotion Understanding to zero to resolve a Heywood Case, the hierarchical model of ability EI shows good fit ($\chi^2[1032, N = 830] = 1205.55, p < .001$; RMSEA = .014; CFI = .921; TLI = .917; WRMR = .855). The average item loading on each factor was: Emotion Perception (.47: range .33 to .59); Emotion Understanding (.39: range -.25 to .81); Emotion Management (.35: range .18 to .61); second-order ability EI (.88: range .80 to 1.0).

Model 3: Various bifactor models, where each of the items loaded once onto its theorized group factor and once onto a general ability EI factor, were tested. Possibly due to the use of item-level analysis, rather than scale-scores as conducted by MacCann et al. (2014), no model converged. Constraining factor variance and relationships between group scores was unsuccessful, as was increasing the number of iterations. As such, a bifactor model was not compatible with the current data.

Model 4: A unidimensional model of the cognitive tests and the ability EI tests together did not show good fit ($\chi^2[2484, N = 830] = 4142.75, p < .001$; RMSEA = .028; CFI = .813; TLI = .808; WRMR = 1.292). The average item loading was .41, ranging from -.21 to .76.

Model 5: A five-factor oblique model with two cognitive ability subfactors and three ability EI subfactors fitted the data well ($\chi^2[2474, N = 830] = 3017.29, p < .001$; RMSEA = .016; CFI = .939; TLI = .937; WRMR = .969). The average item loading on each factor was: Gf (.75: range .65 to .86); Gc (.61: range .33 to .81); Emotion Perception (.46: range .29 to .57); Emotion Understanding (.39: range -.24 to .82); Emotion Management (.34: range .18 to .56). The mean latent factor correlation was .63 (range = .43 to .84).

Model 6: Next, the factor intercorrelations from Model 5 were replaced by a single, higher-order *g* factor. The loadings of the five lower factors onto the higher-order *g* were all strong (ranging from .72 to .90; average = .79). Model fit was good, however slightly worse than the oblique five-factor model ($\chi^2(2479, N = 830) = 3339.76, p < .001$; RMSEA = .020; CFI = .903; TLI = .900; WRMR = 1.068). The average item loading on each factor were: Gf (.75: range .64 to .87); Gc (.61: range .33 to .81); Emotion Perception (.46: range .29 to .57); Emotion Understanding (.39: range -.25 to .82); Emotion Management (.34: range .18 to .54).

Model 7: Ability EI (loaded by three subfacets: Perception, Understanding and Management) was modeled as a second-stratum factor of *g*, alongside fluid and crystallized intelligence. After fixing the factor variance of Gc to zero to resolve a Heywood Case, the model produced good fit to the data ($\chi^2[2479, N = 830] = 3016.59, p < .001$; RMSEA = .016; CFI = .939; TLI = .938; WRMR = .971). The average item loadings were: Gf (.75: range .65 to .86); Gc (.62: range .33 to .82); Emotion Perception (.46: range .29 to .57); Emotion Understanding (.39: range -.24 to .82); Emotion Management (.34: range .18 to .56). Loadings onto the ability EI factor were strong (.88; ranging .82 to .98), and the loading of ability EI onto the *g* factor (.70) was of similar magnitude to the *g*-loadings of fluid intelligence (.74).

Model 8: Various bifactor models, where each of the items loaded once onto the group factor and once onto *g*, were tested. Possibly due to the use of item-level analysis, rather than scale-scores as conducted by MacCann et al. (2014), no model

converged. Constraining factor variance and relationships between group scores was unsuccessful, as was increasing the number of iterations. As such, a bifactor model was not compatible with the current data. Given there is covariance between cognitive abilities, and there are no bifactor theories of intelligence, the assumptions of the bifactor model may be less theoretically appropriate than the alternative models captured (Murray & Johnson, 2013). The lack of a fitting bifactor model was therefore not considered problematic.

In sum, model fit indices suggest the oblique five-factor model and the hierarchical model with ability EI at the second stratum (Models 5 and 7, respectively) represent similarly plausible models of the current data. Given substantive debate surrounding the importance of the *g* factor (McGrew, 2009), both models can be considered concurrent in presenting ability EI at the second-stratum of cognitive ability, and relevant for inclusion in the CHC model.

Discussion

The current study provided a conceptual replication of analyses conducted by MacCann et al. (2014) to examine whether ability EI fits within factor models of broad cognitive ability. Concurrent with the original results and the broad body of evidence highlighting the value of hierarchical models for structuring cognitive abilities, the current paper argues that ability EI can be considered a second-stratum factor of the CHC model. As to whether an oblique or hierarchical model presents the best current available model of understanding, theory should be considered alongside fit indices (Murray & Johnson, 2013). In this regard, the hierarchically structured model which is consistent with the CHC model of intelligence would seem preferable, especially because such a model would require only limited changes as predicted by CHC theory (i.e., the addition of another second-stratum factor; McGrew, 2009). Thus, considering both model fit and well-established theory, the results of the current study are consistent with MacCann et al. (2014) in suggesting that ability EI is best considered as a hierarchically structured (loaded emotion perception, understanding and management) second-stratum factor within the CHC model of intelligence (MacCann et al., 2014).

Beyond replicating the results of MacCann et al. (2014), the current findings provide a unique contribution to our understanding. The current study had a large sample of participants and used different measures for all intelligence and ability EI facets captured. Given the intimate links between the MSCEIT (used by MacCann et al., 2014) and the development of ability EI theory, the replication of these findings using alternative measures provides evidence to indicate that such results are unlikely to represent test effects. Together, the findings provide convincing support for situating ability EI within the CHC model as a second stratum factor of intelligence, separate to fluid or crystallized intelligence.

The measurement and structure of ability EI has been dominated by the MSCEIT (Mayer et al., 2003, formerly MEIS). Thus, the current study adopted alternative nonproprietary measures: an optimized version of the Reading Mind in the Eyes Test (Baron-Cohen et al., 2001; Olderbak et al., 2015), and brief versions of the Situational Test of Emotion Management and Situational Test of Emotion Understanding (Allen, Weissman, Hellwig, MacCann, & Roberts, 2014, 2015). Findings from the data presented suggest

that these other measures provide a viable theoretically appropriate alternative to the proprietary MSCEIT. Due to the financial costs associated with the MSCEIT, there have been a number of calls for alternative free and open-access measures (Mestre, MacCann, Guil, & Roberts, 2016). The measures adopted for the current study address these calls and may offer wider opportunities for research projects to adopt ability EI.

The current study adopted few, and brief, measures to minimize participant fatigue. As a result, there is limited content coverage of intelligence as a whole, and relatively narrow representation of fluid and crystallized intelligence, although scores on the scales adopted closely approximate scores derived from longer measures (Condon & Revelle, 2014). Further replications of the current findings with greater content coverage (using multiple tests of several abilities) are vital to minimize distortion of estimates due to method-related variance and increase the likelihood that bifactor models can be estimated. In addition, future research that develops additional nonproprietary ability EI measures that exhibit excellent psychometric properties would allow for more reliable estimates of construct-level variance. This is a particularly pertinent priority given the psychometric shortcomings of the MSCEIT and the low reliability of the emotion perception and emotion understanding subfactors of the scales used here (see also Austin, 2010; Olderbak et al., 2015).

In sum, the current study adds to the growing body of evidence that situates ability EI within frameworks of cognitive ability, replicating the main conclusions of MacCann et al. (2014). Currently, ability EI best represents a hierarchical construct formed of emotion perception, understanding and management factors, structured as a second stratum factor within the CHC model.

References

- Allen, V. D., Rahman, N., Weissman, A., MacCann, C., & Roberts, R. D. (2015). The Situational Test of Emotional Management–Brief (STEM-B): Development and validation using item response theory and latent class analysis. *Personality and Individual Differences, 81*, 195–200. <http://dx.doi.org/10.1016/j.paid.2015.01.053>
- Allen, V. D., Weissman, A., Hellwig, S., MacCann, C., & Roberts, R. D. (2014). Development of the situational test of emotional understanding—Brief (STEUB) using item response theory. *Personality and Individual Differences, 65*, 3–7. <http://dx.doi.org/10.1016/j.paid.2014.01.051>
- Austin, E. J. (2010). Measurement of ability emotional intelligence: Results for two new tests. *British Journal of Psychology, 101*, 563–578. <http://dx.doi.org/10.1348/000712609X474370>
- Baron-Cohen, S., Wheelwright, S., Hill, J., Raste, Y., & Plumb, I. (2001). The “Reading the Mind in the Eyes” Test revised version: A study with normal adults, and adults with Asperger syndrome or high-functioning autism. *Journal of Child Psychology and Psychiatry, 42*, 241–251. <http://dx.doi.org/10.1111/1469-7610.00715>
- Bentler, P. M., & Bonett, D. G. (1980). Significance tests and goodness of fit in the analysis of covariance structures. *Psychological Bulletin, 88*, 588–606. <http://dx.doi.org/10.1037/0033-2909.88.3.588>
- Bentler, P. M., & Chou, C. P. (1987). Practical issues in structural modeling. *Sociological Methods & Research, 16*, 78–117. <http://dx.doi.org/10.1177/0049124187016001004>
- Bowman, D. B., Markham, P. M., & Roberts, R. D. (2002). Expanding the frontier of human cognitive abilities: so much more than (plain) g! *Learning and Individual Differences, 13*, 127–158. [http://dx.doi.org/10.1016/S1041-6080\(02\)00076-6](http://dx.doi.org/10.1016/S1041-6080(02)00076-6)
- Browne, M. W. (1984). Asymptotically distribution-free methods for the analysis of covariance structures. *British Journal of Mathematical and Statistical Psychology, 37*, 62–83. <http://dx.doi.org/10.1111/j.2044-8317.1984.tb00789.x>
- Browne, M. W., & Cudeck, R. (1993). Alternative ways of assessing model fit. In K. A. Bollen & J. S. Long (Eds.), *Testing structural equation models* (pp. 136–162). Newbury Park, CA: Sage.
- Condon, D. M., & Revelle, W. (2014). The International Cognitive Ability Resource: Development and initial validation of a public-domain measure. *Intelligence, 43*, 52–64. <http://dx.doi.org/10.1016/j.intell.2014.01.004>
- Fan, H., Jackson, T., Yang, X., Tang, W., & Zhang, J. (2010). The factor structure of the Mayer–Salovey–Caruso Emotional Intelligence Test V 2.0 (MSCEIT): A meta-analytic structural equation modeling approach. *Personality and Individual Differences, 48*, 781–785. <http://dx.doi.org/10.1016/j.paid.2010.02.004>
- Fiori, M., Antonietti, J. P., Mikolajczak, M., Luminet, O., Hansenne, M., & Rossier, J. (2014). What is the Ability Emotional Intelligence Test (MSCEIT) good for? An evaluation using item response theory. *PLoS ONE, 9*(6), e98827. <http://dx.doi.org/10.1371/journal.pone.0098827>
- Hu, L. T., & Bentler, P. M. (1999). Cutoff criteria for fit indexes in covariance structure analysis: Conventional criteria versus new alternatives. *Structural Equation Modeling, 6*, 1–55. <http://dx.doi.org/10.1080/10705519909540118>
- Hughes, D., & Evans, T. R. (2018). Putting ‘Emotional Intelligences’ in their place: Introducing the Integrated Model of Affect-related Individual Differences. *Frontiers in Psychology, 9*, 2155. <http://dx.doi.org/10.3389/fpsyg.2018.02155>
- Legree, P. J., Psotka, J., Tremble, T., & Bourne, D. R. (2005). Using Consensus Based Measurement to Assess Emotional Intelligence. In R. Schulze & R. D. Roberts (Eds.), *Emotional intelligence: An international handbook* (pp. 155–179). Ashland, OH: Hogrefe & Huber.
- MacCann, C. (2010). Further examination of emotional intelligence as a standard intelligence: A latent variable analysis of fluid intelligence, crystallized intelligence, and emotional intelligence. *Personality and Individual Differences, 49*, 490–496. <http://dx.doi.org/10.1016/j.paid.2010.05.010>
- MacCann, C., Joseph, D. L., Newman, D. A., & Roberts, R. D. (2014). Emotional intelligence is a second-stratum factor of intelligence: Evidence from hierarchical and bifactor models. *Emotion, 14*, 358–374. <http://dx.doi.org/10.1037/a0034755>
- MacCann, C., & Roberts, R. D. (2008). New paradigms for assessing emotional intelligence: Theory and data. *Emotion, 8*, 540–551. <http://dx.doi.org/10.1037/a0012746>
- Maul, A. (2012). The validity of the Mayer–Salovey–Caruso Emotional Intelligence Test (MSCEIT) as a measure of emotional intelligence. *Emotion Review, 4*, 394–402. <http://dx.doi.org/10.1177/1754073912445811>
- Mayer, J. D., Caruso, D. R., & Salovey, P. (1999). Emotional intelligence meets traditional standards for an intelligence. *Intelligence, 27*, 267–298. [http://dx.doi.org/10.1016/S0160-2896\(99\)00016-1](http://dx.doi.org/10.1016/S0160-2896(99)00016-1)
- Mayer, J. D., Roberts, R. D., & Barsade, S. G. (2008). Human abilities: Emotional intelligence. *Annual Review of Psychology, 59*, 507–536. <http://dx.doi.org/10.1146/annurev.psych.59.103006.093646>
- Mayer, J. D., Salovey, P., Caruso, D. R., & Sitarenios, G. (2001). Emotional intelligence as a standard intelligence. *Emotion, 1*, 232–242. <http://dx.doi.org/10.1037/1528-3542.1.3.232>
- Mayer, J. D., Salovey, P., Caruso, D. R., & Sitarenios, G. (2003). Measuring emotional intelligence with the MSCEIT V2.0. *Emotion, 3*, 97–105. <http://dx.doi.org/10.1037/1528-3542.3.1.97>
- McGrew, K. S. (2009). CHC theory and the human cognitive abilities project: Standing on the shoulders of the giants of psychometric intelligence research. *Intelligence, 37*, 1–10. <http://dx.doi.org/10.1016/j.intell.2008.08.004>

- Mestre, J. M., MacCann, C., Guil, R., & Roberts, R. D. (2016). Models of cognitive ability and emotion can better inform contemporary emotional intelligence frameworks. *Emotion Review*, 8, 322–330. <http://dx.doi.org/10.1177/1754073916650497>
- Murray, A. L., & Johnson, W. (2013). The limitations of model fit in comparing the bi-factor versus higher-order models of human cognitive ability structure. *Intelligence*, 41, 407–422. <http://dx.doi.org/10.1016/j.intell.2013.06.004>
- Muthén, L. K., & Muthén, B. O. (2010). *Mplus user's guide* (6th ed.). Los Angeles, CA: Author.
- Nowicki, S., Jr., & Duke, M. P. (1994). Individual differences in the nonverbal communication of affect: The Diagnostic Analysis of Nonverbal Accuracy Scale. *Journal of Nonverbal Behavior*, 18, 9–35. <http://dx.doi.org/10.1007/BF02169077>
- Nunnally, J. C. (1967). *Psychometric theory*. New York: McGraw-Hill.
- Olderbak, S., Wilhelm, O., Olaru, G., Geiger, M., Brennehan, M. W., & Roberts, R. D. (2015). A psychometric analysis of the reading the mind in the eyes test: Toward a brief form for research and applied settings. *Frontiers in Psychology*, 6, 1503. <http://dx.doi.org/10.3389/fpsyg.2015.01503>
- Palmer, B. R., Gignac, G., Manocha, R., & Stough, C. (2005). A psychometric evaluation of the Mayer–Salovey–Caruso Emotional intelligence test version 2.0. *Intelligence*, 33, 285–305. <http://dx.doi.org/10.1016/j.intell.2004.11.003>

Received January 4, 2018

Revision received July 30, 2018

Accepted December 4, 2018 ■