

The Monotype 4-Line System for Setting Mathematics

by Daniel Rhatigan

Essay submitted in partial fulfilment of the requirements for
the MA in Typeface Design, University of Reading, 2007

Contents

1	Introduction.....	1
2	Monotype metal typesetting.....	3
2.1	Units of measurement	3
2.2	The keyboard.....	5
2.3	The caster	5
2.4	Make-up	7
3	A business opportunity	9
3.1	The difficulty of mathematics	9
3.2	The aftermath of World War II	11
4	The 4-line system.....	13
4.1	Development of the system	15
4.2	Times 4-line Mathematics Series 569.....	17
4.3	Changes to the keyboard.....	19
4.4	Enhancement of the composition caster.....	21
4.5	Final make-up of the galleys	25
5	Conclusion.....	27
	Appendix.....	29
	Works cited	33

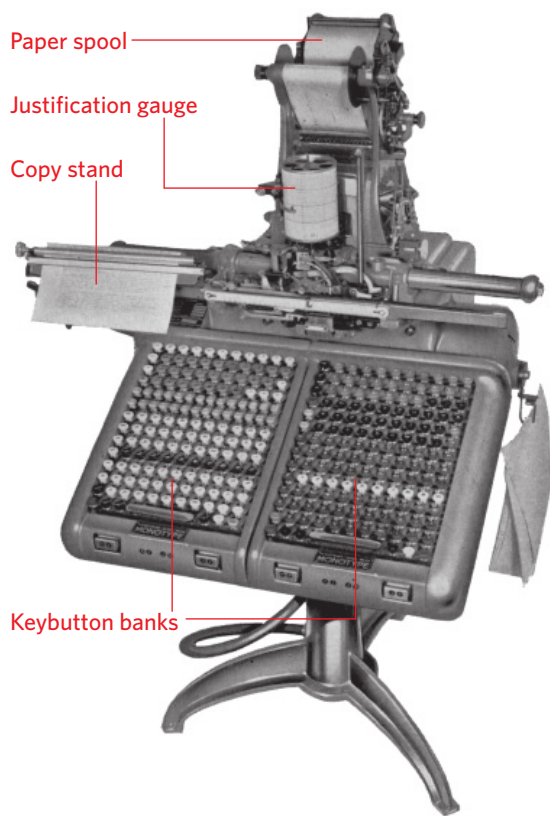

A

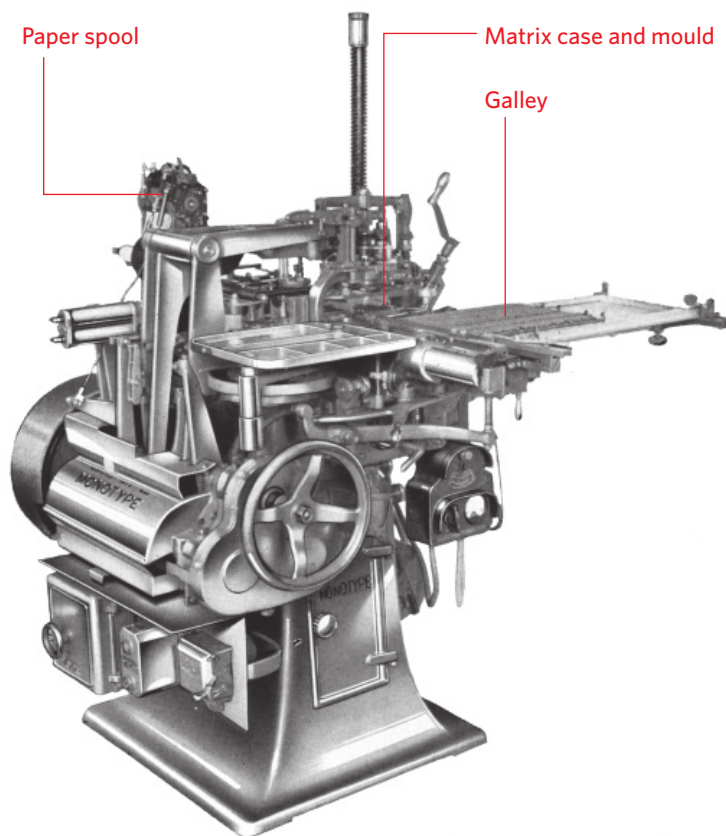

B

Figure 1

A The Monotype "D" keyboard

B The Monotype typecaster

Chaundy, T W, P R Barrett, and Charles Batey. The printing of mathematics. London: Oxford University Press (1954) plates III and IV

1. Introduction

Typesetting any material requires a compositor with the skill to make a number of decisions about how best to meet the demands of the text, but mathematics can be a particularly demanding subject. Using many exotic figures and symbols, mathematical notation often defies the tendency of a typical passage of text to line up letters and numbers one by one, row after row, in an orderly and predictable manner. The detailed notation and complex arrangement found in all but the most basic maths present challenges that traditionally could only be met by compositors with specialised expertise, able to visualize how all these pieces could fit together and then carefully arrange them by hand. In 1957, the Monotype Corporation Limited introduced its 4-line system for mathematics, a technique for mechanically composing mathematical formulae with metal type that would reduce the amount of time-consuming, costly hand-setting needed for mathematics. With this new method, Monotype hoped to automate some of this process without sacrificing any of the quality that had only been possible with hand-setting until that time.

The 4-line system was a modification of existing tools and type designs rather than a fundamentally new technology. Mechanical composition employed intricate machinery requiring an incredible amount of precision, and any changes to it had to work within the constraints of an industrial infrastructure already in place. A development like the 4-line system — in essence a set of mechanical attachments along with a new set of matrices for casting the type itself — may seem straightforward, but it still required years of development, and could only offer a partial solution for composing complex mathematics. Nevertheless, it was a significant enough change to open up the once-exclusive field of mathematical and scientific publishing to a much wider range of printers and establish a new standard for math in print.

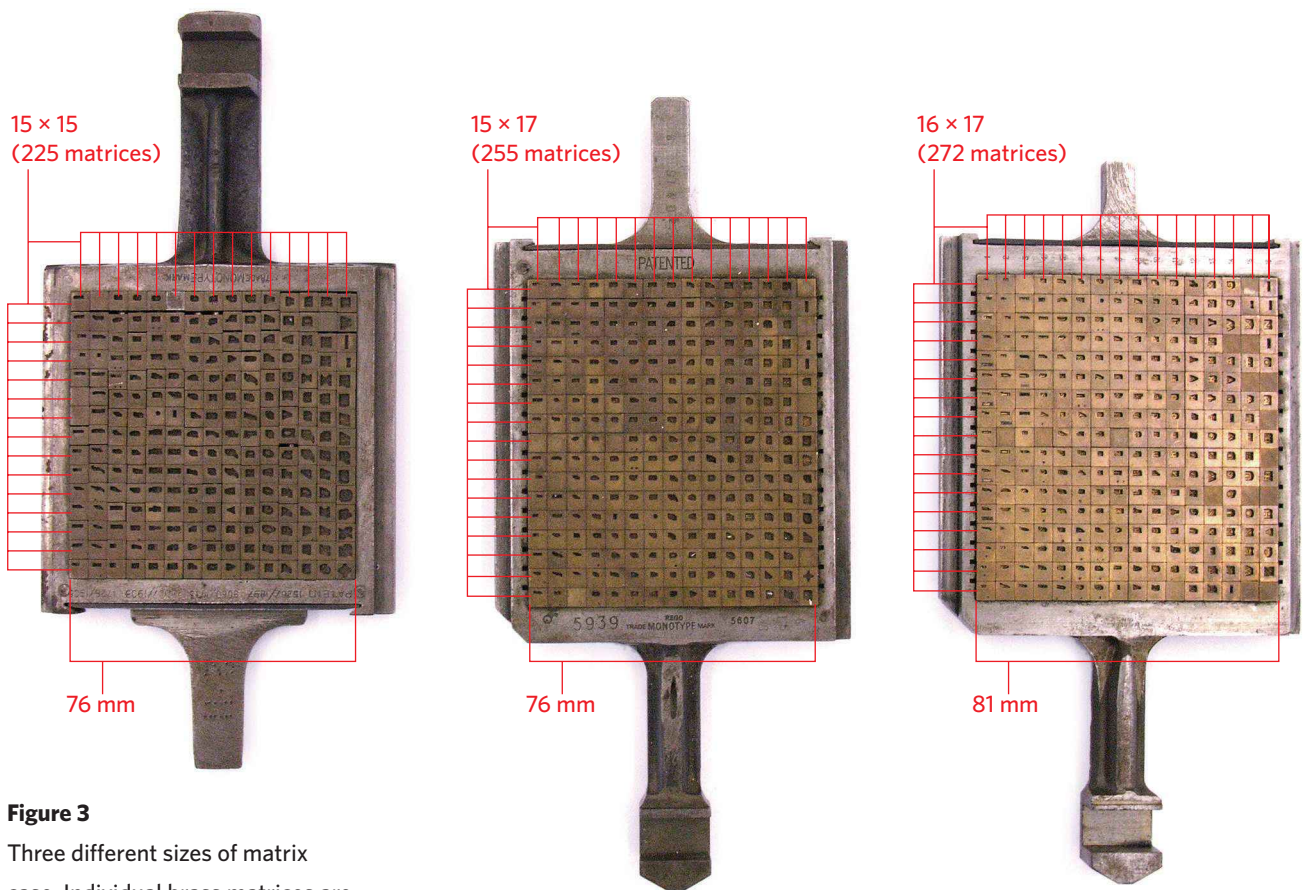

Figure 3

Three different sizes of matrix case. Individual brass matrices are positioned in order of the character's unit width: all the matrices on one row will be used for characters of the same width, and all those on the row below will measure one unit wider. The largest matrix case benefits from a caster attachment called the unit shift, which enables a row to contain characters of two different widths. Over the years Monotype added rows to the matrix case to increase its capacity from 225 (15 × 15) to 255 (15 × 17) and finally to 272 (16 × 17) matrices.

2 Monotype metal typesetting

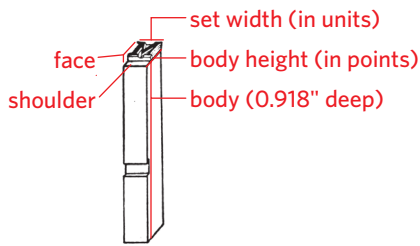

Figure 2

A single type sort, showing the key dimensions and parts mentioned in this essay.

Chaundy et al. *The printing of mathematics*, p. 2

Before examining the details of the 4-line system, it will be helpful to understand the basic equipment and techniques employed by typical Monotype mechanical composition.

The Monotype system mechanically sets text made up of single types — individual characters cast one at a time, lined up, and stacked into galleys of text. The use of individual sorts allows compositors to rearrange the type after casting. This way compositors can make corrections or insert characters that could not be cast at the same time as the bulk of the text, such as those from other fonts or those set at different sizes. This ability to supplement the mechanical process with manual composition made Monotype the ideal choice for certain kinds of printing, such as academic books or other texts whose complexity required great attention to typographic details.

2.1 Units of measurement The Monotype system measures the vertical dimensions of type (body and character sizes) in points. However, it measures horizontal space in terms of the “set width” of any given font. (*See figure 2.*) The set width is generally close to — but rarely equal to — the nominal point size of any given font. For instance, the set width of Times New Roman is $9\frac{3}{4}$ at 10 point. This indicates that the widest character in this particular 10-point typeface, such as the em space, will measure 9.75 points wide. Other typefaces may use a different ratio of set width to point size.

The set width of all fonts is divided into 18 units of space, and all characters and spaces within the font are measured by these units and designed with a minimum width of 4 units and a maximum width of 18 units.¹ (With additional attachments to the keyboard and caster, 3-unit spaces can also be cast.) Since the unit width of a given character may differ from one font to the next, the arrangement of matrices for casting will differ as well. (*See figure 3.*)

¹ Chaundy, T W, P R Barrett, and Charles Batey. *The printing of mathematics*. London: Oxford University Press (1954) p. 6.

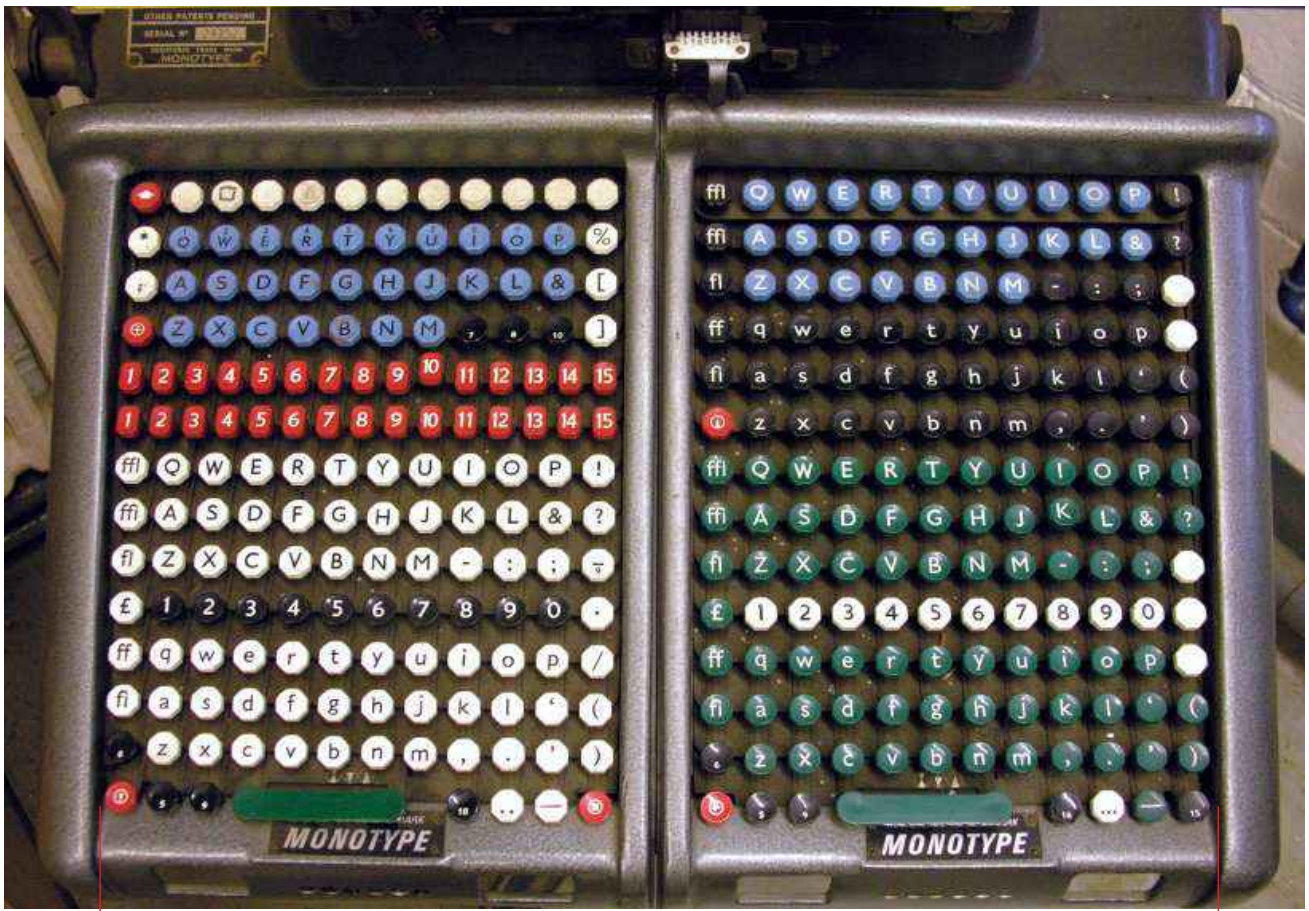

53 cm

Figure 4

A typical keyboard layout with two banks of keybuttons. Duplicate characters placed on differently coloured keys indicate other styles available for those characters, such as italic or small capitals. The two rows of red keys showing numbers from 1 to 15 are used for justifying lines of type with unit spaces.

2.2 The keyboard The first major component of a Monotype system is the keyboard,² a stand-alone device used to produce a perforated tape that specifies the sequence of characters made by the casting machine.

On the keyboard two banks of keybuttons sit side-by-side on a stand (*see figure 4*), each key connected to a lever below called a keybar. The keybars transfer the pressure of the keys above to the internal mechanisms of the keyboard. The stopbar case, a mechanism that must be changed for each font used, counts the units that add up on each line as keys are pressed. Another mechanism uses compressed air to push a series of 31 pistons that perforate a paper tape with a pattern to indicate which part of the matrix case should be held in position above the type mould in the caster. Since the positions of keybuttons is fixed but the layout of the matrix case will change from one font to another, the keybars must be rearranged for each font so that the static keybuttons can always correlate to the varying matrix positions.³

2.3 The caster The composition caster is the unit that creates the lead pieces of type in the sequence specified by the keyboard. The paper tape produced by the keyboard is moved to the caster and loaded onto a spool across which compressed air is blown. As air is forced through the perforations in each row, it moves a series of pistons that drive a complex mechanism to move the matrix case and position the matrix for each specified character over a mould that forms the body of each piece of type.

At the same time, another mechanism adjusts the width of the empty chamber within the mould to the correct set width for the matrix held above. Although the mould adjusts to many different widths, it can only produce one body height. Therefore, a different mould must be used to cast different body sizes.

Once the matrix position and the character width are set, the caster lowers the matrix case onto the mould and pumps molten lead into the mould chamber. The mould shapes the body of the type sort while the matrix shapes the face. Once the lead cools, the caster lifts the matrix

² The keyboard described is the Monotype D keyboard introduced in 1908. The earlier C keyboard with its single bank of keybuttons was never adapted for 4-line mathematics.

³ Stocks, Mick. Demonstration of a Monotype keyboard and caster at the University of Reading (6 December 2006).

case and pushes the sort out the side of the mould and into a channel that carries it to a galley along the side of the caster. This process repeats for all the characters and spaces in each line. When the caster encounters the end-of-line signal on the paper tape, it pushes the line of text up and begins casting and arranging the next line.⁴

2.4 Make-Up After casting the galleys of type, a compositor moves the galley to off the caster, makes any manual adjustments needed, and splits the galleys into individual pages for printing. If passages of text are cast in separate lots for any reason — recall that the caster can only accommodate one body size or one limited set of matrices at a time (*see figure 3*) — this is the stage where the lots are combined and arranged into their final layout.

⁴ Bolton, David. Demonstration of a Monotype keyboard and caster at the Alembic Press, Abingdon, Oxfordshire (2 December 2006).

Figure 5

A diagram from *The Printing of Mathematics* (1954) illustrates the complex arrangement of characters and spaces required to compose mathematics with metal type. Not only are numerous type styles and non-standard symbols mixed together, but characters are set on a wide variety of body sizes. The black rectangles indicate the many sizes of spaces that must be arranged to hold the characters in place. Before the introduction of the 4-line system, expressions like these were composed entirely by hand out of characters cast in multiple batches, requiring the time and skill of a highly trained compositor.



3 A business opportunity

3.1 The difficulty of mathematics Despite the efficiency of the standard Monotype system, mechanical composition could only accommodate the most basic mathematical notation. Simple single-line expressions might be set without manual intervention, but most maths call for a mix of roman and italic characters, numerals, Greek symbols, superior and inferior characters, and many other symbols. To ease the process, printers and Monotype itself often urged authors to use alternate forms of notation that could be set more easily, but the clarity of the subject matter often depended on notation that was more difficult to set. Even if there were room in the matrix case for all the symbols needed at one time, the frequent use of oversize characters, strip rules, and stacked characters and symbols require type set on alternate body sizes and fitted together like a puzzle. This wide variety of type styles and sizes made it costly to set text with even moderately complex mathematics, since so much time and effort went into composing the material by hand at the make-up stage.

Although the Monotype system was still preferred by printers of mathematics, the volume of distinct characters and their complex arrangements forced most printers to assemble equations almost entirely by hand, using casters to produce individual sorts for later assembly and insertion into galleys of mechanically set prose.⁵ Setting maths requires skilled compositors with enough training and experience not only to interpret the instructions in a mathematical manuscript, but also to quickly find and place any of the thousands of different characters that may be needed. This kind of experience restricted mathematics to the specialised printers who worked with the “learned presses” at prestigious universities and professional societies.⁶

⁵ Type could be made in batches on the composition caster, which could use attachments to produce some oversize characters and rules. Larger characters and rules as well as any other sorts could also be made on Monotype’s Super Caster, which could cast a wider variety of material, but only one character or object at a time.

⁶ Chaundy *et al.* *The printing of mathematics*, pp. 11–16.

3.2 The aftermath of World War II After World War II, an explosion of scientific and technical publishing placed a strain on traditional methods for composing mathematics. The printers who had specialised in mathematics already wanted to increase the efficiency and reduce the cost of their operations, and other printers with less experience in the field wanted to try and meet some of this new demand.

The war itself brought a number of changes to Monotype that would influence its direction in the following years. The works at Salford — Monotype's main production facility — were converted to a munitions factory in 1939, severely limiting the company's ability to continue its own product line for the duration of the war. Then on 10 May 1941, the building housing the company's offices and printing school at 43 Fetter Lane in London was destroyed by enemy bombs. Although new offices were soon established nearby, the equipment and records lost in the fire were another substantial blow to the company's operations.⁷

As it resumed production in the wake of the war, Monotype found itself struggling to meet its customers' demands for parts and equipment.⁸ In this climate of an uncertain return to economic stability, it makes sense that the company would choose to develop technology such as the 4-line system that adapted to its existing equipment and working methods, rather than solutions that would make unrealistic demands on the company's ability to devise and manufacture new kinds of equipment altogether.

⁷ Wallis, Lawrence W. 'Monotype time check', *The Monotype Recorder*, new series (10) (1997) p. 50.

⁸ The Monotype Corporation Limited. *Book of information*, 2nd edn. London: The Monotype Corporation Limited (1970) p. 8.

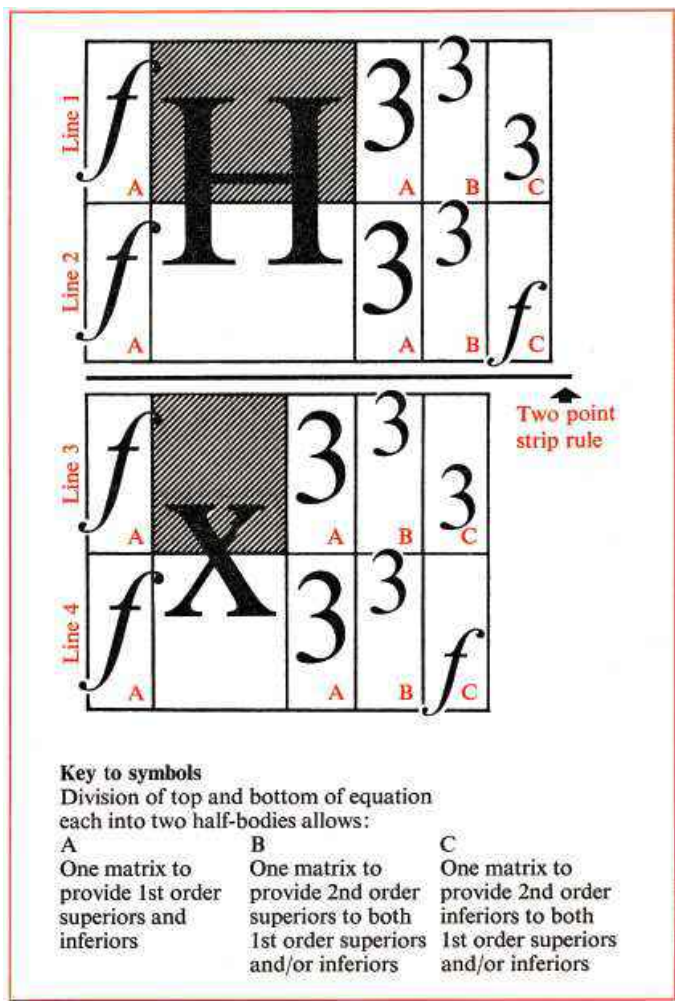

Figure 7

This diagram shows how characters of different sizes can be arranged within a 4-line equation. Character details that extend past the edge of any rectangle indicate kerns that must be supported by shoulder-high spaces, strip rules, or the shoulders of adjacent characters.

Poole, J E. Mathematical Formulae. London: The Monotype Corporation Limited (1971) p. 2

4 The 4-line system

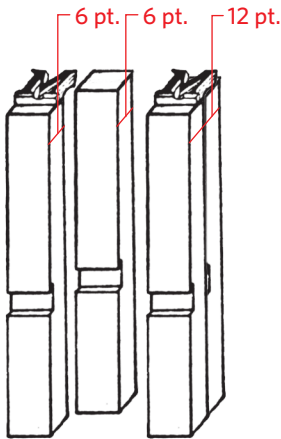

Figure 6

Diagram showing how the overhanging face of 10-point type cast on a 6-point body rests on a 6-point shoulder-high space, effectively working as a sort with a 12-point body.

The 4-line system is a combination of special matrices, attachments for the keyboard and composition caster, and procedures for making up galleys after casting. Equations are still set separate from the body text and inserted later, but the system allows more complex equations to be cast with minimal manual intervention, speeding up the overall process of composing math considerably.

Rather than casting type on a body size that matched its point size, 4-line equations are planned as four rows of characters set on a half-size body and then stacked together. (See figure 6.) Characters are set at 10 points on 6-point bodies, with overhanging details supported by shoulder-high spaces of the same width set in the line above. Full-size characters therefore take up two rows of the equation, while inferiors and superiors (which would have little or no overhanging detail) can be placed on either of those rows as needed. (See figure 7.)

Breaking a line into two halves allows the same matrices to create characters placed either as inferiors or a superiors of the first order. This duplicity of function frees up many positions in the matrix case for additional characters. Second-order characters — those set inferior or superior to first-order inferiors or superiors — require separate matrices, although these can still be cast on 6-point bodies like other characters.

A compositor inserts strip rules or oversize characters after casting and arranges any other details of the equation that do not fit within the basic arrangement of four lines.⁹

⁹ The Monotype Corporation Limited. *Information sheet no. 156: 4-line mathematics*. London: The Monotype Corporation Limited (1959) pp. 1–2.

$$\int \cosh^{-1} \left(\frac{n_1^2 - \sigma_1^2}{1 - \sigma_1^2} \right)^{1/2} \frac{d\sigma_1}{\sigma_1}$$

A

$$\sum_k' K_0 \left(\frac{|r - r_k|}{L} \right) = \frac{2\pi L^2}{\sigma}$$

B

Figure 8

In these sample equations, the red lines indicate the top and bottom edges of each row of type in the equation.

A An equation set with the Patton method for 4-line maths. Monotype's customers refused to accept the broken and uneven horizontal rules.

B An equation set with Monotype's method. Note the 2-point-high strip rules inserted between the second and third rows of the equation.

The William Byrd Press. Mathematics in type. Richmond, VA: The William Bird Press (1954) p. 16

The Monotype Corporation Limited. Information sheet no. 156: 4-line mathematics. London: The Monotype Corporation Limited (1959) p. 4

4.1 Development of the system In 1952, the Monotype Corporation in the United Kingdom first heard of a 4-line technique called the Patton method being used in North America by the Lanston Monotype Machine Company.^{10,11} From this came the idea of casting letters on a half-height body, as well as using a deletion mechanism to cast shoulder-high blanks based on the width of characters themselves, rather than casting them from blank matrices. In the Patton method, however, the horizontal fraction rule was built up from line segments cast as part of the characters in the third row of the equation. Monotype originally hoped to duplicate this technique of dealing with the rule, but the specialist printers they consulted found the end result inferior to the quality they were able to achieve with hand composition of pre-cast type and strip rules. (See figure 8.)

Working with feedback from the learned presses and Arthur Phillips of Her Majesty's Stationery Office (HMSO), along with engineering assistance from the firm of Sir Isaac Pitman & Son,¹² Monotype spent the next six years perfecting its own implementation of a 4-line system that could set a wider variety of equations with its keyboard and caster. They circulated the first trial results in 1954, receiving feedback that convinced them to recut of many of the characters used. They finally announced the 4-line system at a special exhibition at Monotype House in 1957, and Oliver and Boyd Limited of Edinburgh purchased the first installation of the system in June 1958.¹³

Somewhere between 700 and 800 different matrices were prepared for the initial release, but by 1971 this number had grown to over 8,000 different matrices, with up to five new matrices still being added each week. Considering that many characters could be positioned as either

¹⁰ Poole, J E. *Mathematical formulae*. London: The Monotype Corporation Limited (1971) p. 1.

¹¹ The William Byrd Press. *Mathematics in type*. Richmond, VA: The William Bird Press (1954) p. ix.

The Patton method was named for Wade H. Patton, who designed the method for the Lanston Monotype Machine Company in the United States. Although the Monotype Corporation in the UK was originally spawned from its US counterpart, the two functioned as entirely separate entities.

¹² Poole, J E. 'Mechanising mathematics', *Monotype Newsletter*. 81 (1967) pp. 19–22.

¹³ Anonymous. "Monotype' 4-line composition solves mathematical setting headaches', *Printing News* (25 September 1958) p. 3.

Most important is the result of calculating $\sum_k^\infty f(r_k)$ for a lattice with a cell in the form of a parallelogram the sides of which are a_1 and a_2 , the angle between them being ω .

When computing the sums of f the integral representation of $K_0(x)$ may be used.

$$2\pi L^2 \sum_c f(r) = K_0\left(\frac{r}{L}\right) = \int_0^\infty e^{-(z + \frac{r^2}{4L^2 z})} \frac{dz}{2z}. \tag{11.2}$$

Then summing, according to the Poisson rules gives⁽⁵⁾

$$\sum_k' K_0\left(\frac{|\mathbf{r} - \mathbf{r}_k|}{L}\right) = \frac{2\pi L^2}{\sigma} \sum_{\nu_1, \nu_2} \frac{e^{2\pi i (\frac{\nu_1}{a_1} x + \frac{\nu_2}{a_2} y)}}{\left[1 + \frac{4\pi^2 L^2}{\sin^2 \omega} \left(\frac{\nu_1^2}{a_1^2} + \frac{\nu_2^2}{a_2^2} - \frac{2\nu_1 \nu_2}{a_1 a_2} \cos \omega\right)\right]}. \tag{12.2}$$

If the conditions $\frac{4\pi L^2}{a_1 a_2 \sin^2 \omega} \gg 1$ are fulfilled, then

$$\sum_k' K_0\left(\frac{|\mathbf{r} - \mathbf{r}_k|}{L}\right) = \frac{2\pi L^2}{\sigma} \left(1 + \frac{\sin^2 \omega}{4\pi^2 L^2} \sum_{\nu_1, \nu_2}' \frac{e^{2\pi i (\frac{\nu_1}{a_1} x + \frac{\nu_2}{a_2} y)}}{\left(\frac{\nu_1^2}{a_1^2} + \frac{\nu_2^2}{a_2^2} - \frac{2\nu_1 \nu_2}{a_1 a_2} \cos \omega\right)} \right) \tag{13.2}$$

σ is the area of the lattice-cell; a prime means that the term with $\nu_1 = \nu_2 = 0$ must be dropped.

Thermal utilization θ of an infinite lattice where $K_\infty = 1$, in the absence

Conventional setting of an extract from "Progress in Nuclear Physics and Mathematics" (Pergamon Press)

Most important is the result of calculating $\sum_k^\infty f(r_k)$ for a lattice with a cell in the form of a parallelogram the sides of which are a_1 and a_2 , the angle between them being ω .

When computing the sums of f the integral representation of $K_0(x)$ may be used.

$$2\pi L^2 \sum_c f(r) = K_0\left(\frac{r}{L}\right) = \int_0^\infty e^{-(z + \frac{r^2}{4L^2 z})} \frac{dz}{2z}. \tag{11.2}$$

Then summing, according to the Poisson rules gives⁽⁵⁾

$$\sum_k' K_0\left(\frac{|\mathbf{r} - \mathbf{r}_k|}{L}\right) = \frac{2\pi L^2}{\sigma} \sum_{\nu_1, \nu_2} \frac{e^{2\pi i (\frac{\nu_1}{a_1} x + \frac{\nu_2}{a_2} y)}}{\left[1 + \frac{4\pi^2 L^2}{\sin^2 \omega} \left(\frac{\nu_1^2}{a_1^2} + \frac{\nu_2^2}{a_2^2} - \frac{2\nu_1 \nu_2}{a_1 a_2} \cos \omega\right)\right]}. \tag{12.2}$$

If the conditions $\frac{4\pi L^2}{a_1 a_2 \sin^2 \omega} \gg 1$ are fulfilled, then

$$\sum_k' K_0\left(\frac{|\mathbf{r} - \mathbf{r}_k|}{L}\right) = \frac{2\pi L^2}{\sigma} \left(1 + \frac{\sin^2 \omega}{4\pi^2 L^2} \sum_{\nu_1, \nu_2}' \frac{e^{2\pi i (\frac{\nu_1}{a_1} x + \frac{\nu_2}{a_2} y)}}{\left(\frac{\nu_1^2}{a_1^2} + \frac{\nu_2^2}{a_2^2} - \frac{2\nu_1 \nu_2}{a_1 a_2} \cos \omega\right)} \right) \tag{13.2}$$

σ is the area of the lattice-cell; a prime means that the term with $\nu_1 = \nu_2 = 0$ must be dropped.

Thermal utilization θ of an infinite lattice where $K_\infty = 1$, in the absence of

Resetting by the Four-line System of the extract shown above.

Figure 9 *opposite*

Sample mathematics set by hand and with the 4-line system, taken from *Monotype information sheet no. 156* (March 1959). The hand-set sample uses Modern Series 7, with additional characters taken from Bold face Series 53 and Greek Series 106. In the 4-line sample set with Series 569, the symbols show proportions and spacing that better match the text characters throughout.

$$\frac{\sin^2 \omega}{4\pi^2 L^2} \sum'_{\nu_1, \nu_2}$$

A

$$\frac{\sin^2 \omega}{4\pi^2 L^2} \sum'_{\nu_1, \nu_2}$$

B

Figure 10

A Modern Series 7 composed by hand.

B Times New Roman Series 569 set with the 4-line system.

These details (magnified 2×) from the sample above show the improvements offered with Series 569. Overall the text is slightly narrower, and features less contrast. Numerals have a lighter color and more open counters that improve their clarity at small sizes. Greek characters are drawn with a compatible x-height to that of the roman. Since the design of the series anticipates combinations found in maths, characters such as the italic L have kerns for better positioning of smaller characters.

superiors or inferiors, this actually reflected over 11,000 available characters that were available for 4-line maths.¹⁴

4.2 Times 4-line Mathematics Series 569 For the sake of expediency, Monotype chose to develop a single type series for the 4-line system — a variation of its popular Times New Roman Series 327,¹⁵ which at the time had only a few matching maths symbols. During the development of Times 4-line Mathematics Series 569, as the new series became known, many characters were redrawn to minimize the need for kerning and optimize, where appropriate, the reuse of matrices for both superior and inferior characters. Greek characters, operators, and other mathematical symbols previously cut for other series were added to Series 569 and redrawn to harmonise with its overall design. New matrices were also made for oversized fence characters (brackets, braces, parentheses, etc.) in sizes up to 26 point. Although many symbols already existed in other series, samples show that they did not mix with one another as consistently as they would in Series 569. (See figures 9 and 10.)

Before the introduction of the 4-line system, guides to mathematical composition consistently recommended Monotype's Modern Series 7 for text featuring maths, even though they noted Times New Roman as another acceptable choice. Greek characters were most often set with Greek Series 106 (Porson), which included more characters cut for use as math symbols than any other Greek face.^{16,17} With so much

¹⁴ Poole, *Mathematical formulae*, p. 2.

¹⁵ Monotype identified the type families created for its metal and film equipment with a series number. In the case of Times New Roman, the basic text face as designed by Stanley Morison was designated Series 327, but other variations were given other series numbers. Although the font introduced for 4-line maths was still a Times New Roman design, it was officially designated Series 569 because it contained a distinct set of characters from the original.

¹⁶ Phillips, Arthur. 'Setting mathematics', *The Monotype Recorder*. 40 (4) (1956) p. 10. Phillips refers to a 1950 report by The Royal Society Consultative Committee for Co-operation with Printing Organizations that concluded that mathematical works should be restricted to Modern Series 7, Imprint Series 101, or Baskerville.

¹⁷ Anonymous. 'Mathematical setting: Letterpress printer must give high standard to avoid the diverting of orders, says Arthur Phillips', *Printing World* (23 January 1957) p. 78.

In a presentation given at Monotype House Phillips also mentions Sir Cyril Burt's *Psychological Study of Typography*, which declared that Modern Series 7 was the type-face that mathematicians and scientists expect to see in their publications.

precedent for the use of other series, why then would Monotype put so much effort into developing a new Times New Roman series for the 4-line system?

A growing number of requests for additional matrices convinced Monotype that Times was becoming more popular for technical publications, and would be a strategic choice to bring to market at that time.¹⁸ Although its customers might have preferred more typographic choices, the lengthy process of creating new matrices for the vast number of characters needed for mathematics would have been too costly to repeat for multiple series, or even for additional point sizes within a single series.¹⁹

Recall that Monotype was urged by its customers to abandon some of the principles of the Patton method and develop a better technique of their own. Customer reactions to the 1954 trials of the 4-line system also led to changes in many symbols used in Series 569. It is presumable that the specialist printers saw Monotype's investment in this new system — and its willingness to consult with some of its influential customers — as an opportunity not just to match the quality of what was capable with hand-set type, but to exceed it in terms of typographic consistency and clarity. If new characters were to be cut, there would be an excellent opportunity to bring the full set in line with the primary text face once and for all. This all involved a substantial investment of labor on Monotype's part that reflects its commitment to establishing a new standard for typographic quality with the 4-line system.

4.3 Changes to the keyboard The use of any new series requires new equipment for the keyboard: a new set of stopbars to mark the correct set width for each character on the paper tape, a new arrangement of keybars to coordinate keybutton positions with the rest of the keyboard components, and even a new justification gauge to help the operator calculate the available space at the end of the measure.

¹⁸ Poole, *Mathematical formulae*, p. 2.

¹⁹ The Monotype Corporation Limited. *A pocket picture book of 'Monotype' machines*. London: The Monotype Corporation Limited (n.d., ca. 1965) p. 23.

From the creation of working drawings to the final stage of quality control for a matrix, Monotype went through 82 steps to create each new character in any of its series.



Figure 11

A comparison of a typical keyboard layout (as shown in figure 4) with one arranged for setting 4-line maths.

A keyboard used for a lot of mathematical work would also benefit from custom keybutton banks showing the most commonly used maths characters. (See figures 11 and 12.)

These alternate components might be needed by any new type series. The 4-line system, though, also requires the use of a special “continuous deletion” key. With this key depressed, the keyboard records the widths of a sequence of characters while telling the caster to form shoulder-high spaces of the same width rather than forming the characters themselves. These blank spaces created with a 6-point body either support the overhanging full-size characters on the following row of an equation, or hold the space above or below an inferior or superior character.²⁰ (See figure 7.)

Planning the correct keying sequence is a critical part of the training for a keyboard operator setting maths. Rather reading through manuscript text in a linear fashion, the operator needs to examine each equation in a manuscript, determine how much of it can be set mechanically, and then how the characters and symbols within that equation should be positioned within the 4 available lines. (See figure 13.) For any characters that cannot be set in line with the others (characters larger than 12 points, for example, or additional symbols that could not be fit into the matrix case), spaces of equal width (removed by the compositor later) are needed to hold their position for justification.

4.4 Enhancement of the composition caster Maths composition is easier with the later models of composition caster that can use larger matrix cases to hold more matrices. Additionally, 4-line composition requires additional attachments to accommodate the complex spacing methods set by the keyboard. An attachment for creating a 3-unit space (rather than the typical 4-unit minimum) was used, as well as a special wedge that enabled smaller spacing increments.

The maths attachment itself is actually a series of components that allow the caster to create the shoulder-high spaces based on character widths from the keyboard, rather than using predefined spaces with their own matrices. As noted earlier, any characters that span two rows of an equation must be keyed twice: in the top row they are keyed along with the delete key, and then they are keyed again in the following row. When the caster encounters the delete-key notation

²⁰ Information sheet no. 156, p. 2.

MATRIX-CASE ARRANGEMENT 8196 Wedge 5

UNITS	N	L	A	B	C	E	F	E	F	G	H	I	J	K	L	M	N	O
5	I	ˆ	ˆ	ˆ	ˆ	ˆ	ˆ	ˆ	ˆ	ˆ	ˆ	ˆ	ˆ	ˆ	ˆ	ˆ	ˆ	ˆ
6	J	f	t	l	ˆ	(.	,	ˆ	i	l	j	f	t	-	()	
7	s	!	I	r	s	;)	-	f	t	!	r	s	I	:	;	!	
8	F	E	:	;	z	v	c	e	ˆ	s	r	I	:	e	c	v	z	
9	B	T	b	p	o	*	J	c	e	z	u	d	q	1	2	3	£	
9	P	J	h	q	n	g	?	g	x	g	o	b	h	4	5	6	7	
9	L	?	y	u	d	a	.	-	£	a	n	p	y	8	9	0	?	
10	Q	z	y	v	a	x	1	2	ˆ	3	4	5	6	7	8	9	0	
10	Y	V	C	O	R	A	k	x	f	fl	fi	fl	x	k	fi	fl	J	
11	K	H	G	D	N	F	S	d	o	n	u	q	p	h	b	k	S	
12	M	B	P	T	L	E	w	ff	u	ff	Z	P	ff	S	T	F	B	
13	K	V	F	L	B	C	T	E	w	A	R	E	L	C	V	P	Y	
14	Q	U	X	Y	G	N	R	A	Z	ˆ	w	V	C	X	K	Z	m	
15	w	H	D	O	m	&	R	O	A	Y	Q	X	U	N	D	G	&	
18	ff	ff	K	H	G	fl	fl	D	m	U	N	fl	fl	O	H	Q	ˆ	
18	0/4	W	2	M	2	M	2	W	x	M	=	W	9	3	2	10	2	

NI NL A B C E F E F G H I J K L M N O

Heavy rule above a character indicates that Unit Shift is incorporated. The unit value of any character so marked must be taken from the unit row immediately above.

Series 327 with 334
(also series 421, 427, 627*)
5 to 14 point.

This matrix-case provides for:
A to Z & A to z a to z ffffff
1 to 0 .,:;!?-()*(/£-.-.-.-.-.°
A to Z ˆ a to z ffffff .,:;!?
A to Z& a to z ffffff
1 to 0 .,:;!?-()£-

* Flanged -030 at side in 327-12, 14 pt., 421-10, 11, 12 pt., and 427-11, 12, 14 pt.
* Extended setwise in 327-14 pt., 421-11, 12 pt., 427-12, 14 pt.
* Outside in 327-14 pt., 421-11, 12 pt., 427-12, 14 pt.
* 327 Series only.
* Flanged -030 at side in 327-12, 14 pt., 421-11, 12 pt., and 427-11, 12, 14 pt.
* Flanged -030 at side in 427-12 pt.
* Extended setwise in 327-14 pt., 421-11, 12 pt., and 427-14 pt.
* Outside in 327-14 pt., 421-11, 12 pt., and 427-14 pt.
* Extended setwise in 334-14 pt.
* Outside for 327-14 pt., 421-11, 12 pt., and 427-12, 14 pt.

Two unit values are obtainable from fixed spaces by use of Unit Shift.

Series 327/334

5	3D	6D
5	31	61
64	64	74
74	74	SET

8	9	10	11	12	14	POINT
84	94	104	12	124	SET	

*For details of these series, see reverse of this layout.

KEYBOARD ARRANGEMENT
Keybar 85011

14	ˆ	ˆ	ˆ	ˆ	ˆ	ˆ	ˆ	ˆ	ˆ	ˆ	ˆ	ˆ	ˆ	ˆ	ˆ	ˆ	ˆ	ˆ
13	*	Q	W	E	R	T	Y	U	I	O	P	0/°						
12	.	A	S	D	F	G	H	J	K	L	ˆ	ˆ	ˆ	ˆ	ˆ	ˆ	ˆ	ˆ
11	⊕	Z	X	C	V	B	N	M	ˆ	ˆ	ˆ	ˆ	ˆ	ˆ	ˆ	ˆ	ˆ	ˆ
10	⊙	⊙	⊙	⊙	⊙	⊙	⊙	⊙	⊙	⊙	⊙	⊙	⊙	⊙	⊙	⊙	⊙	⊙
9	⊙	⊙	⊙	⊙	⊙	⊙	⊙	⊙	⊙	⊙	⊙	⊙	⊙	⊙	⊙	⊙	⊙	⊙
8	ff	Q	W	E	R	T	Y	U	I	O	P	!						
7	ff	A	S	D	F	G	H	J	K	L	&	?						
6	fl	Z	X	C	V	B	N	M	-	:	;	-						
5	£	l	2	3	4	5	6	7	8	9	0	ˆ	ˆ	ˆ	ˆ	ˆ	ˆ	ˆ
4	ff	q	w	e	r	t	y	u	i	o	p	/						
3	fi	a	s	d	f	g	h	j	k	l	ˆ	ˆ	ˆ	ˆ	ˆ	ˆ	ˆ	ˆ
2	ˆ	z	x	c	v	b	n	m	.	?	;	;	;	;	;	;	;	;
1	⊕	ˆ	ˆ	ˆ	ˆ	ˆ	ˆ	ˆ	ˆ	ˆ	ˆ	ˆ	ˆ	ˆ	ˆ	ˆ	ˆ	ˆ

SPACE KEY

Stopbar 5

Keybar 85012

14	ff	Q	W	E	R	T	Y	U	I	O	P	!
13	ff	A	S	D	F	G	H	J	K	L	ˆ	?
12	ff	Z	X	C	V	B	N	M	-	:	;	ˆ
11	ff	q	w	e	r	t	y	u	i	o	p	ˆ
10	fi	a	s	d	f	g	h	j	k	l	ˆ	ˆ
9	⊙	z	x	c	v	b	n	m	.	?	;	ˆ
8	ff	Q	W	E	R	T	Y	U	I	O	P	!
7	ff	A	S	D	F	G	H	J	K	L	&	?
6	fl	Z	X	C	V	B	N	M	-	:	;	ˆ
5	£	l	2	3	4	5	6	7	8	9	0	ˆ
4	ff	q	w	e	r	t	y	u	i	o	p	ˆ
3	fi	a	s	d	f	g	h	j	k	l	ˆ	ˆ
2	ˆ	z	x	c	v	b	n	m	.	?	;	ˆ
1	⊕	ˆ	ˆ	ˆ	ˆ	ˆ	ˆ	ˆ	ˆ	ˆ	ˆ	ˆ

SPACE KEY

- ⊙ Quadder
- ⊕ Repeater
- ⊕ for Duplex Keyboard
- ⊕ for Duplex Keyboard
- ˆ Blank in matrix-case
- ⊙ Justification
- ˆ Key not in use
- ˆ Low space
- ⊙ Letterspace
- ⊙ Variable space
- ⊙ Reverse
- ˆ Unit Shift

A

Figure 12 this page and opposite
Keyboard and matrix layouts for
Times New Roman Series 327 (A)
compared with those for Times 4-line
Mathematics Series 569 (B).

	NI	NL	A	B	C	D	E	F	G	H	I	J	K	L	M	N	O
†3		,	.	i	j	l	.	,	□		/	r	s	()	f	j
†4	i	l	.	◇	◇	◇	◇	◇	◇	◇	◇	◇	◇	◇	◇	◇	◇
6	t	()	j	l	e	d	k	□	g	u	y	b	c	◇	◇	◇
6	f	/	f	i	i	g	h	j	o	n	v	x	a	◇	◇	◇	◇
7	r	s	s	:	:	!	ε	p	x	◇	◇	◇	◇	◇	◇	◇	◇
8	[{	c	c	c	r	γ	v	±	±	f	7	8	9	o	◇	◇
8]	}	z	l	e	v	ζ	τ	1	2	3	4	5	6	?	◇	◇
9	a	g	v	y	∂	z	6	7	□	8	9	0	α	η	θ	m	w
9	x		L	o	±	±	±	1	2	3	4	5	*	χ	δ	λ	ζ
10	b	d	n	p	u	a	h	k	p	x	y	κ	π	σ	◇	◇	◇
10	h	k	o	q	J	b	d	n	q	u	g	μ	ρ	β	◇	◇	◇
12	B	E	F	P	Z	w	Γ	Δ	Ξ	ψ	+	-	φ	◇	◇	◇	◇
†11	Y	V	T	S	R	G	C	A	w	D	O	Q	Σ	Λ	Φ	Ω	ω
15	m	H	W	K	N	U	X	m	√	Π	Ψ	Θ	◇	◇	◇	◇	◇
18	M	...	→	≡	×	±	~	~	<	>	-	=	+	◇	◇	◇	□
	NI	NL	A	B	C	D	E	F	G	H	I	J	K	L	M	N	O

255 characters and spaces are accommodated in the 15×17 matrix-case. To meet exceptional demand, a 16×17 matrix-case can be used, giving 17 extra positions.

Keybars 10454

Stopbars 1141

Keybars 10455

Γ Δ Θ Λ Ξ Π Σ Φ Ψ Ω ·	14			*	G2	H2	I2	J2	K2	L2	□	
⊙ ⊙ ⊙ ⊙ ⊙ ⊙ ⊙ ⊙ ⊙ ⊙ ⊙ ⊙ ⊙ ⊙ ⊙ ⊙	13	⊙	L12	M12	N12	O12	K14	L14	M14	N14	O14	M15
⊙ ⊙ ⊙ ⊙ ⊙ ⊙ ⊙ ⊙ ⊙ ⊙ ⊙ ⊙ ⊙ ⊙ ⊙ ⊙	12	⊙	N6	O6	N7	O7	M10	N10	O10	M11	N11	O11
‡Rr Q W E R T Y U I O P	11	±	q	w	e	r	t	y	u	i	o	p
◇ A S D F G H J K L ?	10	½	a	s	d	f	g	h	j	k	l	□
N15 Z X C V B N M : ; !	9	½	z	x	c	v	b	n	m	M5	N5	O5
L15 ± < > √ ≡ ~ ~ → × ...	8		[]	/	±	±	H5	I5	J5	K5	L5
α β γ δ ε ζ η θ κ λ μ	7	M2	N2	O2	M3	N3	O3	L4	M4	N4	O4	□
v ξ π ρ σ τ φ χ ψ ω ∂	6	C2	D2	E2	F2	G2	H2	I2	J2	K2	L2	□
= 1 2 3 4 5 6 7 8 9 0	5	B2	1	2	3	4	5	6	7	8	9	0
+ q w e r t y u i o p	4	+	q	w	e	r	t	y	u	i	o	p
- a s d f g h j k l (3	-	a	s	d	f	g	h	j	k	l	(
□ z x c v b n m , .)	2	/	z	x	c	v	b	n	m	□	□)
Delete □ □ □ □ □ □ □ □ □ □	1	○	[]	{	}	□	□	□	□	□	□

- ⊙ Justification key
- Low space
- Key not in use
- ⇨ Letterspace key
- ◇ Blank in matrix-case
- ⊙ High Space

§ For quadding and centring device

* Refer to keybank row 14 for alternative 4-unit values

† 5-unit values, 6-unit values from matrix-case row 2, and 13-unit values, are obtained by automatic Unit-Adding

For further details, prices or demonstration, apply to THE MONOTYPE CORPORATION LIMITED
 Reg. Office: Monotype House REGISTERED TRADE MARK
 43 Fetter Lane, London E.C.4 **MONOTYPE**
 HEAD OFFICE & WORKS: SALFORDS, REDHILL, SURREY

B

Figure 13

This diagram shows the proper way to plan a keying sequence for an equation with full-size characters as well as inferiors and superiors. For each line keyed, white boxes indicate shoulder-high spaces created by keying the character shown immediately above or below while the delete key is depressed. Grey boxes indicate characters keyed normally without using the delete key.

Information sheet no. 156: 4-line mathematics, p. 2

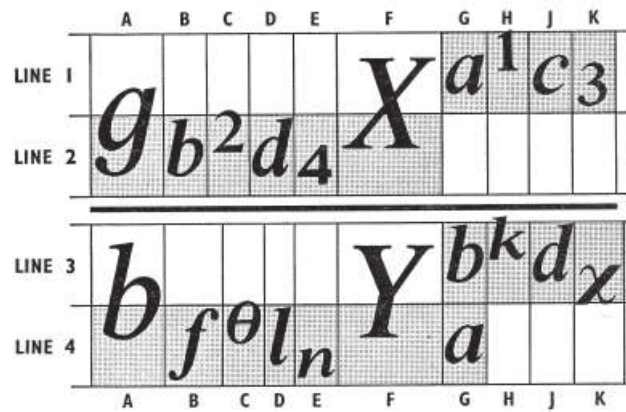

LINE 1. A, B, C, D, E, F: Shoulder-high spaces of the same unit-widths as characters below. G: 6-pt. character positioned as a first-order superior (compare 4G). H: Second-order superior. J: As 1G. K: Second-order inferior.

LINE 2. A: 10-pt. character with overhang protruding upwards. B: 6-pt. character positioned as a first-order inferior. C: Second-order superior. D: As 2B (compare 3j). E: Second-order inferior. F: As 2A. G, H, J, K: Shoulder-high spaces of the same unit-widths as characters above.

LINE 3. A, B, C, D, E, F: As line 1 A, B, C, D, E, F. G: As 1G (character cast from same matrix as used for 2B). H: As 1H. J: As 1G (character cast from same matrix as used for 2D). K: As 1K.

LINE 4. A, B, C, D, E, F: As line 2 A, B, C, D, E, F. G: As 2B (character cast from same matrix as used for 1G). Note first-order superior above. H, J, K: As 2G, H, J, K.

on the paper tape, the maths attachment slides a small blade between the matrix case and the mould so that the molten lead will fill the mould chamber (set to the correct width for the character) but not the matrix itself. This creates a sort that perfectly matches the width of the intended character, but with nothing cast above the shoulder height. The resulting blank sort can then support the overhanging detail of the same character in the following row, or fill a gap between other characters in the equation.

Monotype also recommended a slightly different mixture of lead for 4-line maths, a formula containing 10% tin and 10% antimony (the standard mixture was 10% tin and 16% antimony) that is slightly less durable but flows more easily into the very fine details of the matrices for small characters and delicate overhangs.²¹

4.5 Final make-up of the galleys The 4-line system still assumes that a certain amount of hand composition will be required after the casting process. Horizontal rules, oversize characters, and any additional symbols must be inserted once the galley is removed from the caster. Some forms of notation require more complex arrangement than the system accommodates, so sorts must be rearranged by hand to compose them. Also, since the 4-line system uses a different size of mould than any surrounding text would use, lines of math are still cast separately from the text and integrated later.

Certainly, printers would have preferred a solution that eliminated slow, costly hand-setting altogether. The 4-line system was a significant improvement, though: it increased the speed of maths composition by an average of 26 percent.²² By transferring a significant portion of the work to the keyboard operator — a set of skills that could be more easily trained than those of the make-up compositor — printers from outside the specialised world of the learned presses were able to compete for the business of producing mathematical and technical publications with a minimal change in the of duties of their employees.

²¹ *Information sheet no. 156*, p. 1–2.

²² Phillips, 'Setting mathematics', p. 24.

5 Conclusion

Although unable to automate the maths composition entirely, the 4-line system nevertheless transformed the printing of mathematics. Once 4-line maths were introduced, sources described Monotype's method as the standard technique for such material.²³ Series 569 and the principles of the 4-line layout were even adapted for Monophoto — Monotype's filmsetting technology²⁴ — and their relevance carried on until the digital era demanded other solutions for setting mathematics.

In one sense, 4-line mathematics was an elegant solution to a difficult problem. With a few deft adaptations of its keyboard and caster — and the decision to consolidate a hodge-podge of typeforms into one well-designed family — Monotype was able to open the field of mathematics publishing to more of its customers and also raise the standard of typographic quality for those who had already dominated that field. The elegance of their solution, though, was perhaps offset by the challenges of its execution. The Monotype Corporation as we know it today — a licensor and distributor of software products based on its intellectual property — is not the manufacturer of precision industrial equipment that it was in the 1950s. At that time, a change in technology as relatively minor as the 4-line system still took half a decade to perfect. Series 569 was based on the existing design of the Times New Roman family, yet it took at least two decades for Monotype to design and produce the matrices needed for its vast character set.

A change in working method, a change in typefaces — in the era of mechanised metal typesetting, these called for a massive investment of materials, time, and labor. Today, when an individual can be his own digital foundry, compositor, and publisher — when complex mathematics can be set with freely available software tools — it can be challenging to appreciate the scope of Monotype's achievement with the 4-line system. This change in method and typeface, however, brought new value to hot-metal composition in era when even Monotype itself was already looking for other ways to set type.

²³ Wick, Karel. *Rules for type-setting mathematics*, Prague: Publishing House of the Czechoslovak Academy of Sciences (1965) p. 12.

²⁴ Poole, J E. 'Filmsetter mathematics', *Monotype Newsletter*. 82 (1967) p. 2.

Monotype's own literature continued to assert the usefulness of 4-line metal composition over filmsetting for some kinds of notation.

Appendix

Most literature about the 4-line system describes the typographic developments and the concepts behind planning and keying an equation in a 4-line arrangement, with only a cursory mention of the special attachments required for the system to function properly. Images of the maths attachments are understandably rare, since the attachments themselves are barely visible once they have been installed and do not suggest much about their function when seen on their own. Catalogues of Monotype spare parts, however, show images of the individual pieces that make up the continuous deletion attachment for the keyboard and the special maths attachment for the composition caster. The maths attachments may have each had a simple mechanical function, but the complexity of these parts suggests the scope of the engineering effort that went into their creation.

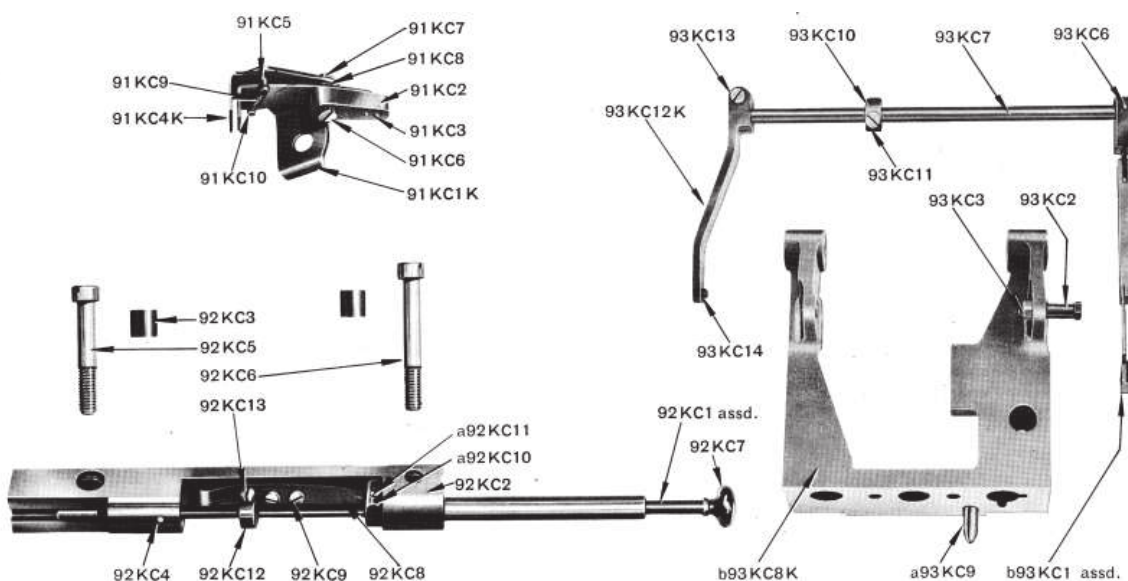

Figure 14

The individual parts that comprise
Monotype component 44KU,
Continuous Delete Attachment

The Monotype Corporation Limited.
Spare parts list for 'Monotype'
standard and deluxe keyboards
comprising illustrations of sections
and component parts with their
names and symbols. *Salford, Redhill,*
Surry: Monotype Corporation Limited
(n.d., ca. 1970)

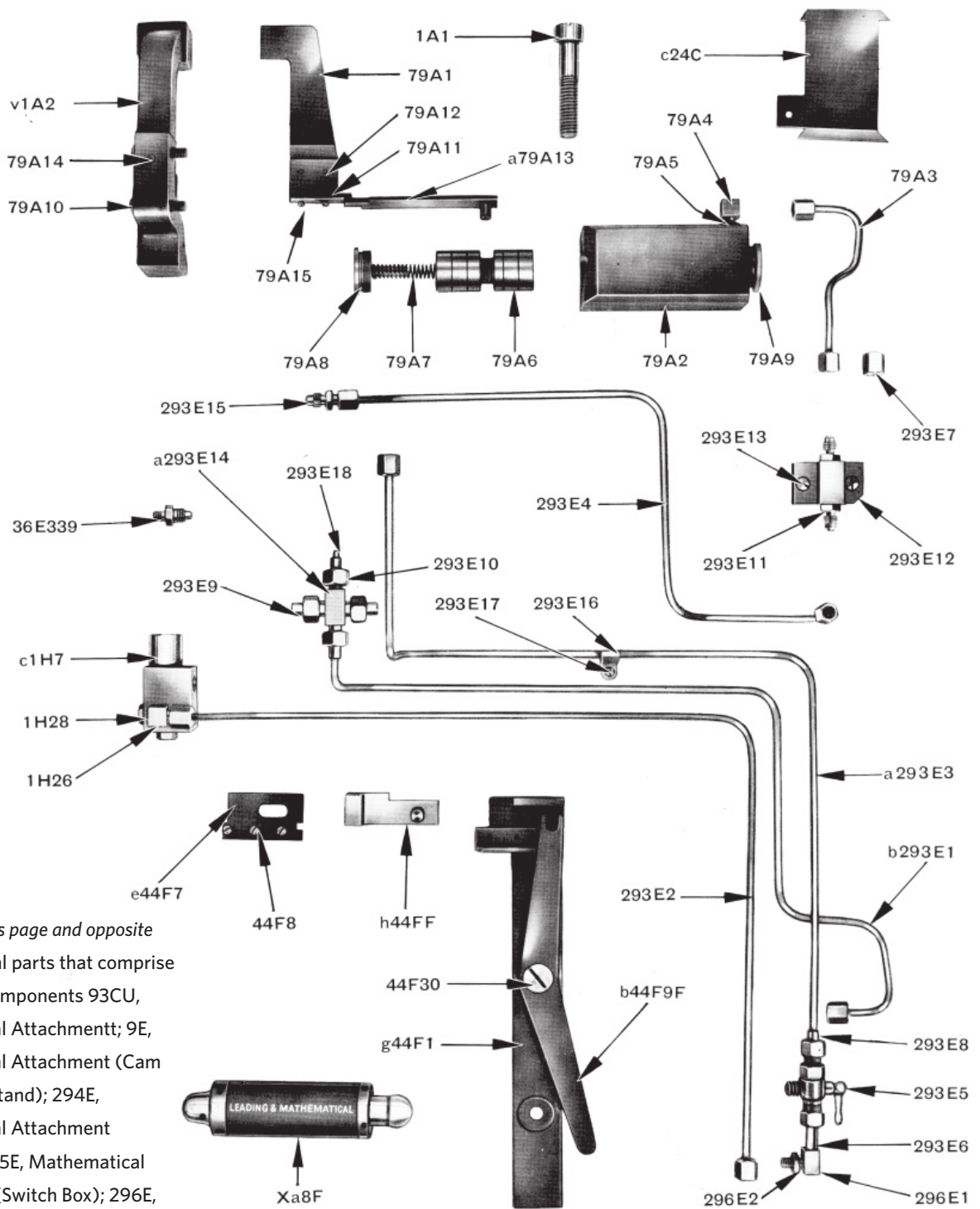
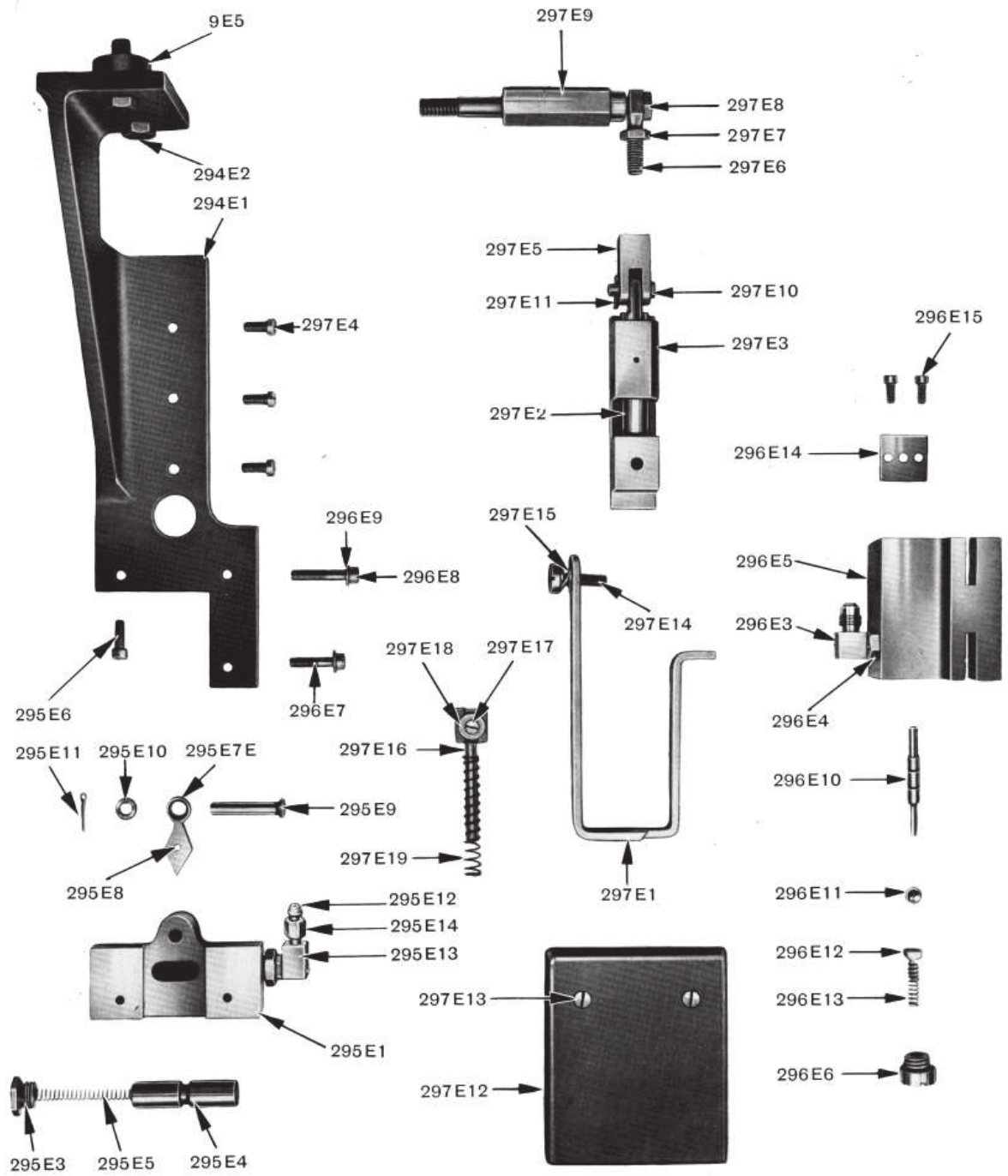

Figure 15 this page and opposite
 The individual parts that comprise
 Monotype components 93CU,
 Mathematical Attachment; 9E,
 Mathematical Attachment (Cam
 Lever Shaft Stand); 294E,
 Mathematical Attachment
 (Bracket); 295E, Mathematical
 Attachment (Switch Box); 296E,
 Mathematical Attachment (Valve
 Box "Mathematical"); and 297E,
 Mathematical Attachment (Valve
 Operating Arm)

The Monotype Corporation Limited.
 Spare parts list for 'Monotype' type and
 rule casters comprising illustrations
 of sections and component parts with
 their names and symbols. *Salford,*
Redhill, Surry: Monotype Corporation
Limited (n.d., ca. 1970)



Works cited

Anonymous

'Mathematical setting: Letterpress printer must give high standard to avoid the diverting of orders, says Arthur Phillips', *Printing World* (23 January 1958) p. 78

Anonymous

'Monotype' 4-line composition solves mathematical setting headaches', *Printing News* (25 September 1958) p. 3

Bolton, David

Demonstration of Monotype keyboard and caster
(2 December 2006)

Chaundy, T W, P R Barrett, and Charles Batey

The printing of mathematics. London: Oxford University Press (1954)

The Monotype Corporation Limited

Book of information, 2nd edn. London: The Monotype Corporation Limited (1970)

The Monotype Corporation Limited

Information sheet no. 156: 4-line mathematics. London: The Monotype Corporation Limited (1959)

The Monotype Corporation Limited

A pocket picture book of 'Monotype' machines. London: The Monotype Corporation Limited (n.d., ca. 1965)

The Monotype Corporation Limited

Spare parts list for 'Monotype' standard and deluxe keyboards comprising illustrations of sections and component parts with their names and symbols. Salfords, Redhill, Surrey: The Monotype Corporation Limited (n.d., ca. 1970)

The Monotype Corporation Limited

Spare parts list for 'Monotype' type and rule casters comprising illustrations of sections and component parts with their names and symbols. Salfords, Redhill, Surrey: The Monotype Corporation Limited (n.d., ca. 1970)

Phillips, Arthur

'Mathematical typography', *Print in Britain*. 4 (12) (1957) 358–61.

Phillips, Arthur

‘Setting mathematics’, *The Monotype Recorder*. 40 (4) (1957)

Poole, J E

‘Filmsetter mathematics’, *Monotype Newsletter*. 82 (1967) 2–4.

Poole, J E

‘Mechanising mathematics’, *Monotype Newsletter*. 81 (1967) 19–22

Poole, J E

Mathematical formulae. London: The Monotype Corporation Limited (1971)

Saunders, David

‘Two Decades of Change, 1965–1986’, *The Monotype Recorder*. new series (10) (1997) 26–35

Stocks, Mick

Demonstration of a Monotype keyboard and caster at the University of Reading (6 December 2006)

Wallis, Lawrence W

‘Monotype Time Check’, *The Monotype Recorder*. new series (10) (1997) 46–55.

Wick, Karel

Rules for type-setting mathematics. Prague: Publishing House of the Czechoslovak Academy of Sciences (1965)

The William Byrd Press

Mathematics in type. Richmond, VA: The William Bird Press (1954)